

Contents

1. Introduction
2. Fluids
- 3. Physics of Microfluidic Systems**
4. Microfabrication Technologies
5. Flow Control
6. Micropumps
7. Sensors
8. Ink-Jet Technology
9. Liquid Handling
10. Microarrays
11. Microreactors
12. Analytical Chips
13. Particle-Laden Fluids
 - a. Measurement Techniques
 - b. Fundamentals of Biotechnology
 - c. High-Throughput Screening

3.A. Simulation

- **Objective for simulation**
- Two prominent types of simulation
 - CFD
 - Resources
 - Basics of the method
 - Examples
 - System
 - Resources
 - Basics
 - Examples
- Conclusions & Summary

Objective for Simulation

Goal: Prediction of system behavior under
given temporal and spatial boundary conditions

Approach:

Model generation: Implementation of device or system
as „mathematical“ model

Simulation: Determination of performance of system or
device by solving model (numerically)

Validation / verification : Testing model by comparison
with experimental data

Model Generation

- **Determination of system boundaries**
 - Where does system start and end?
 - Constituents?
- **Identification of relevant effects**
 - What physical processes need to be considered?
 - Fluid flow?
 - Heat transfer?
 - Chemical reactions?
 - Etc.
- **Determination of model parameters**
 - Shape
 - Size
 - Material
 - Actuation
 - Etc.

Model Generation

- **Mathematical formulation of model**

- In commercial tools usually done by solver
- User only sets parameters and boundary conditions
- Taking mutual interactions of components into account

- **Multiphysics modeling**

- Reduction of complexity
- **Model reduction**

Process of model generation is essential part of simulation!

A simulation only as good as underlying model!

Solving of Model: Simulation

1. Analytical solution

For some „simple“ cases, analytical solutions can be found

2. Numerical solution

The solution calculated by computers and various numerical techniques

Solution in space & time
„physical simulation“

(e.g., finite element method (FEM) for mechanical simulation)

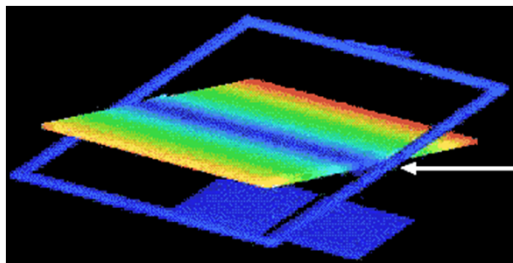

Two-axis mirror assembly

Solution in time
„system simulation“

(e.g., electronic circuit simulation)

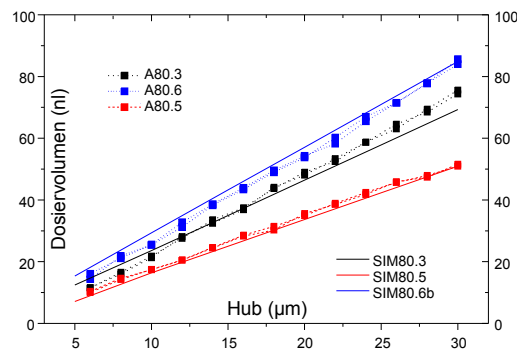

Event oriented
„digital simulation“

(e.g., digital circuit simulation)

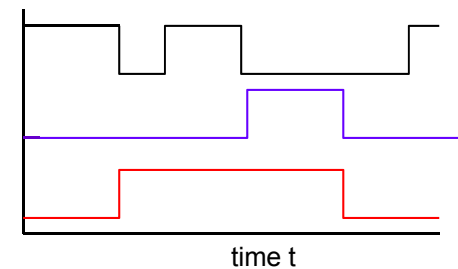

Objective of Simulation

- Reduced development time & cost
 - CAD of MEMS devices
 - Automated optimization of designs
 - Less hardware in loop optimizations
 - Virtual prototyping & testing of device
- Gaining insight and understanding
 - Leads to novel ideas
 - Leads to improved concepts
- Easy testing of new concepts & ideas

3.A. Simulation

- Motivation: What is simulation good for?
- Two prominent types of simulation: CFD and system simulation
- CFD simulation:
 - Resources
 - Basics of the method
 - Examples
- System simulation
 - Resources
 - Basics
 - Examples
- Conclusions & Summary

Types of Simulation

Grid-based „physical“ simulation System or network simulation

- Simulation of solids (mechanical, electrical, thermal and other domains)

- ANSYS
- NASTRAN, ...

- **Simulation of Flow (Computational Fluid Dynamics (CFD))**

- FLUENT
- POLYFLOW
- FLOW-3D

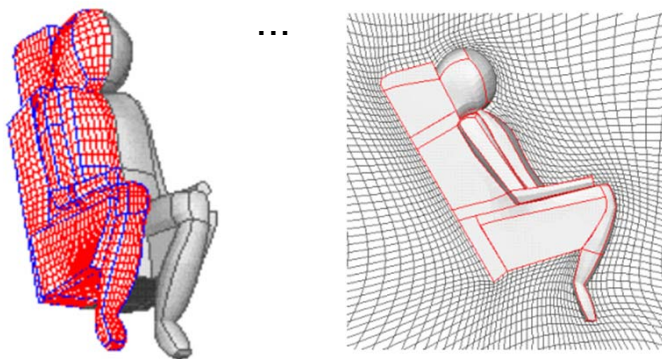

- Simulation based on equivalent circuit diagrams

- SPICE
 - Simulation of electric circuits
- SABER
 - Multi-physics simulation

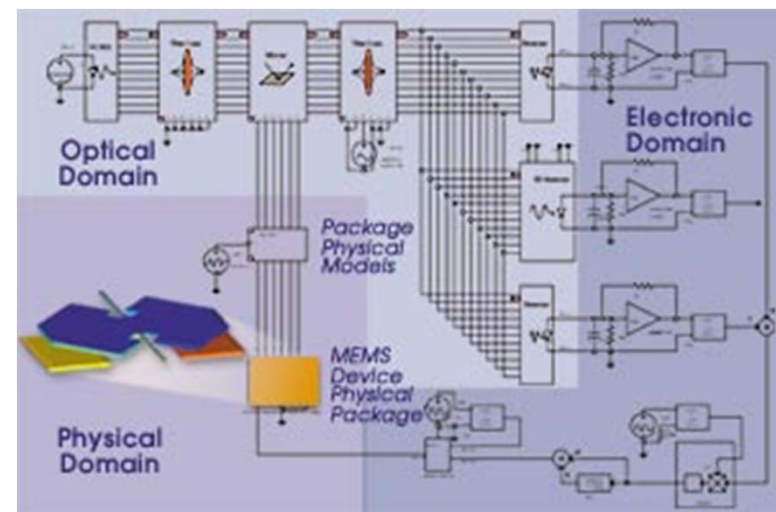

Design-Flow

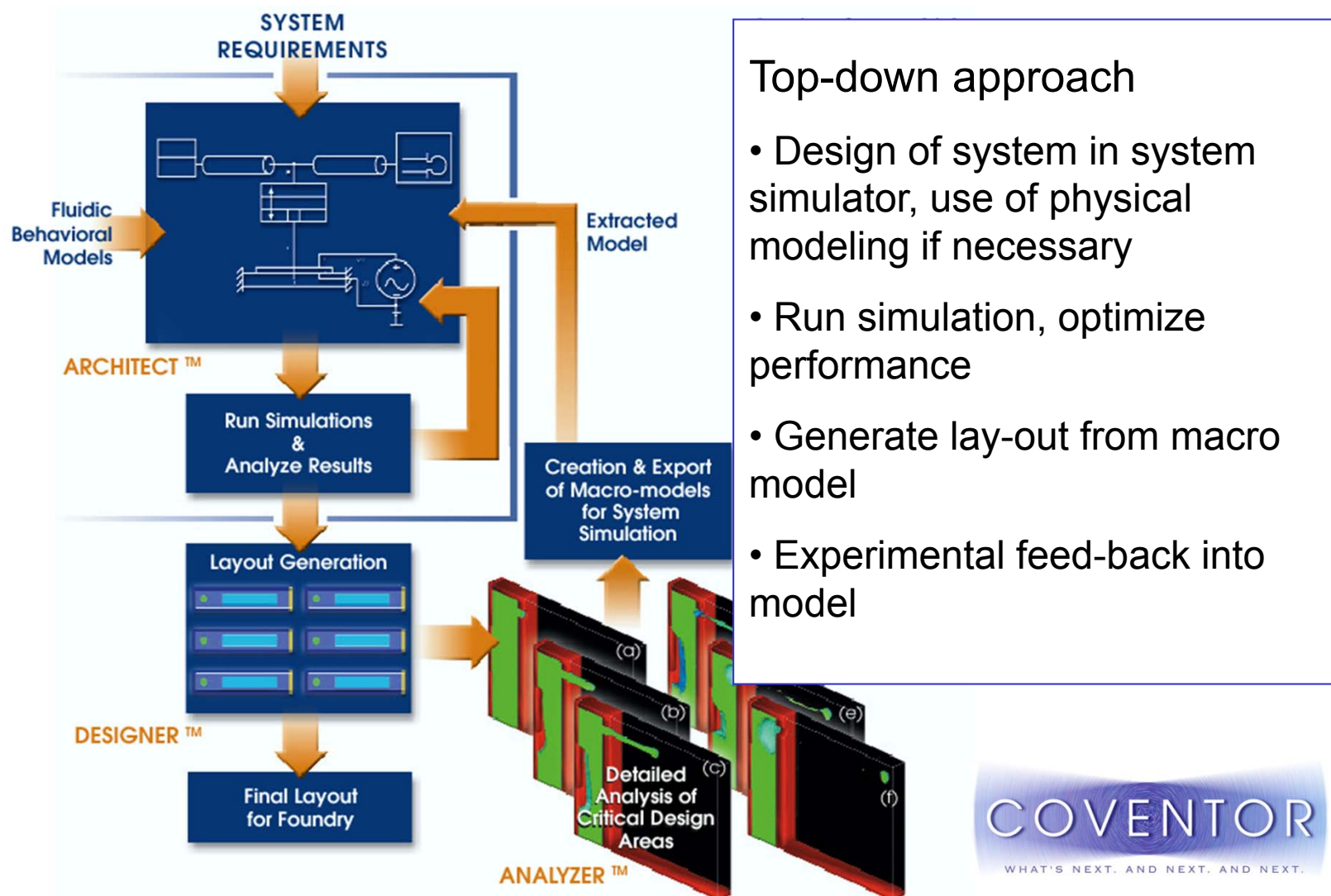

Top-down approach

- Design of system in system simulator, use of physical modeling if necessary
- Run simulation, optimize performance
- Generate lay-out from macro model
- Experimental feed-back into model

Multiphysics Modeling

- Multiphysics means that in most cases more than one physical domain has to be considered. For example:
 - Fluidics & heat transfer (e.g., microreactors)
 - Mechanics & electric engineering (e.g., inertial sensors)
 - Fluidics & electrokinetics & chemistry (e.g., lab-on-a-chip)
- Multiphysics modeling can be done on „physical“ level as well as on system level
 - Coupling of different grid-based solvers (physical level)
 - Defining different physical domains in network simulations (system level)
 - Coupling of grid-based solvers with network (simulation mixed level)

3.A. Simulation

- Motivation: What is simulation good for?
- Two prominent types of simulation: CFD and system simulation
- **CFD simulation:**
 - Resources
 - Basics of the method
 - Examples
- System simulation
 - Resources
 - Basics
 - Examples
- Conclusions & Summary

Simulated F-16/ACES-II Ejection

Time = 0.00 sec

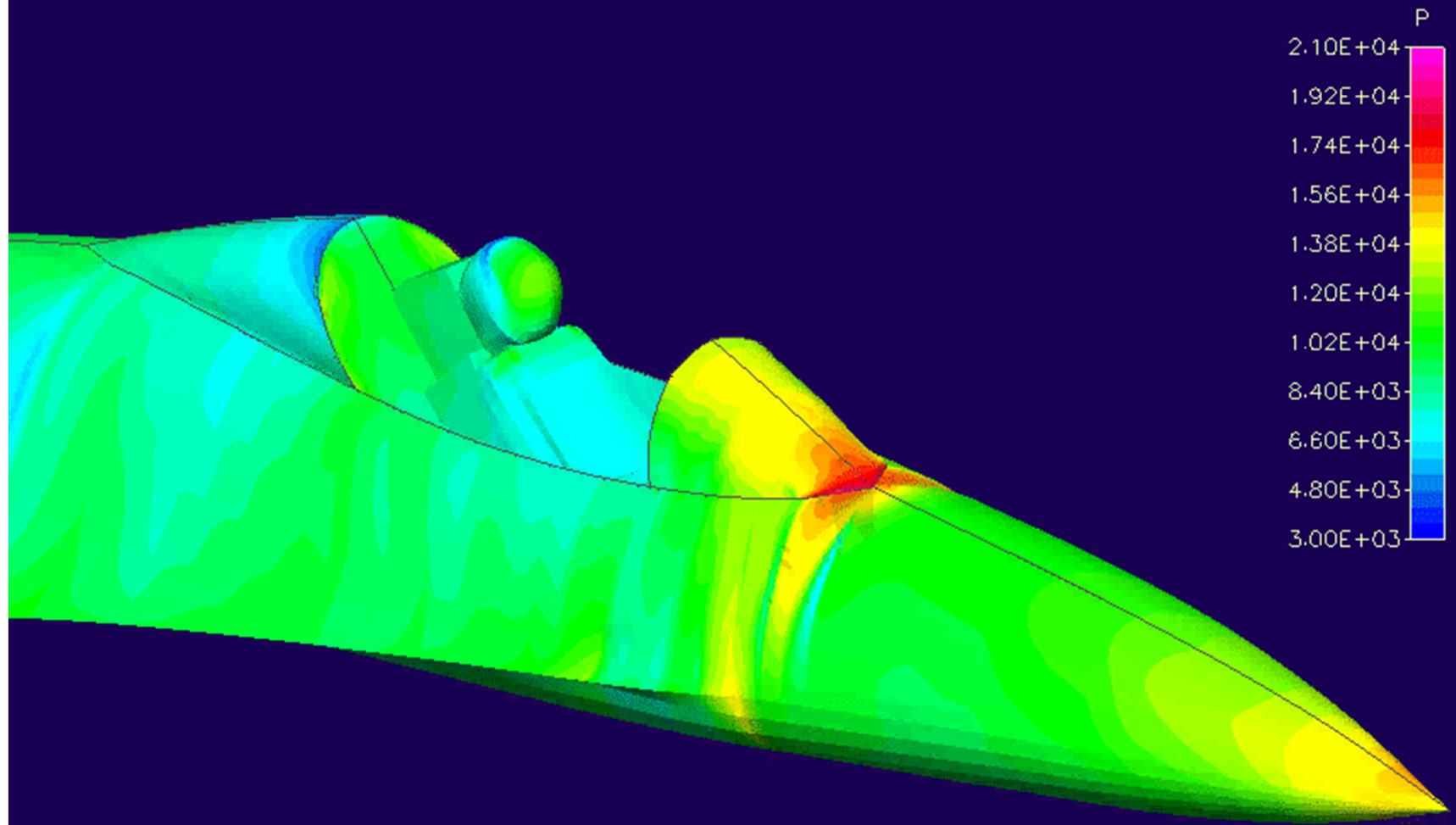

Resources

- CFD-Online: Sponsored information service for CFD-users
<http://www.cfd-online.com>
 - <http://www.cfd-online.com/Resources/homes.html#Company> companies and suppliers
 - <http://www.cfd-online.com/Forum/> discussion and information forum
- Hompages of commercial suppliers of software
 - <http://www.software.aeat.com/cfx>
 - <http://www.fluent.com>
 - <http://www.flow-3D.com>
 - <http://www.cfdrc.com>
 - ...
- Service providers for MEMS (not only CFD)
 - <http://www.memscap.com>
 - <http://www.coventor.com>
 - ...

Physical Foundations of CFD

Navier-Stokes-Equations

$$\rho_{\infty} \left[\frac{\partial}{\partial t} \mathbf{v} + (\mathbf{v} \cdot \nabla) \mathbf{v} \right] = -\nabla p + \eta \nabla^2 \mathbf{v} + \rho_{\infty} \mathbf{g} + ?$$
$$\nabla \cdot \mathbf{v} = 0$$

↑
additional expressions

- ? Expression for capillary forces (surface tension)
- ? Expression for electrokinetic effects (electrophoresis, electroosmosis)
- ? Multi-phase transport $\mathbf{v} = \{\mathbf{v}_1, \mathbf{v}_2, \mathbf{v}_3, \dots\}$
- ? Chemical reactions $\nabla \cdot \mathbf{v} \neq 0$
- ? Etc.

Example 1: Discrete Particle Transport

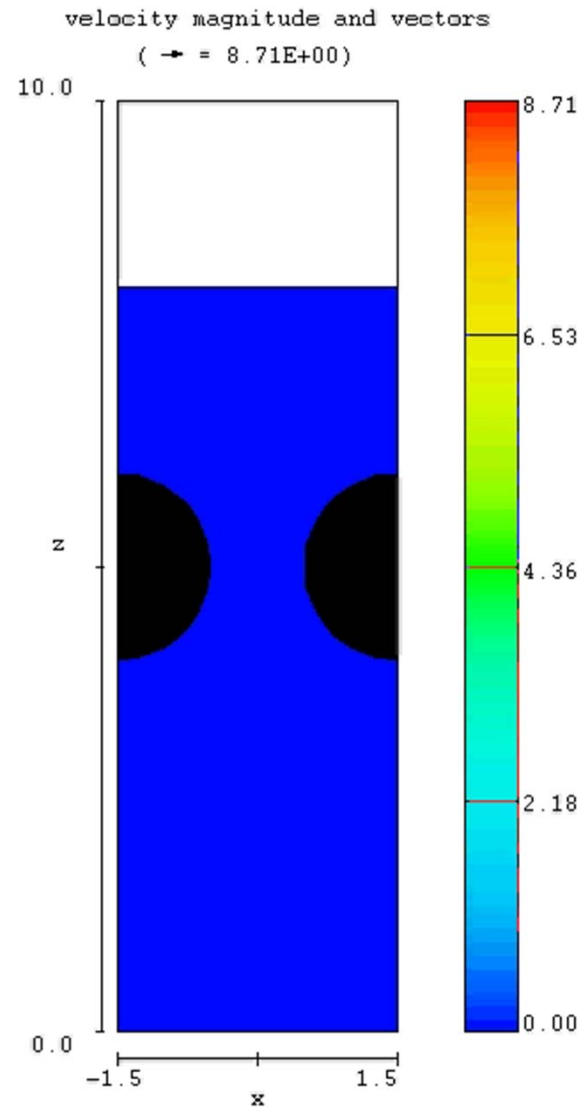

Considered effects:

- Fluid dynamics
- Particle transport

FLOW SCIENCE

Example 2: Welding

Considered effects:

- Fluid dynamics
(two phase flow)
- Heat transfer
- Phase transition

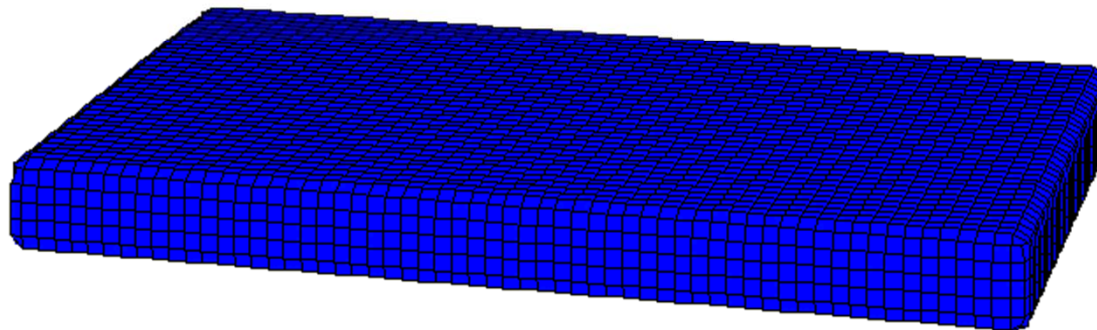

FLOW SCIENCE

Example 3: Dielectrophoresis

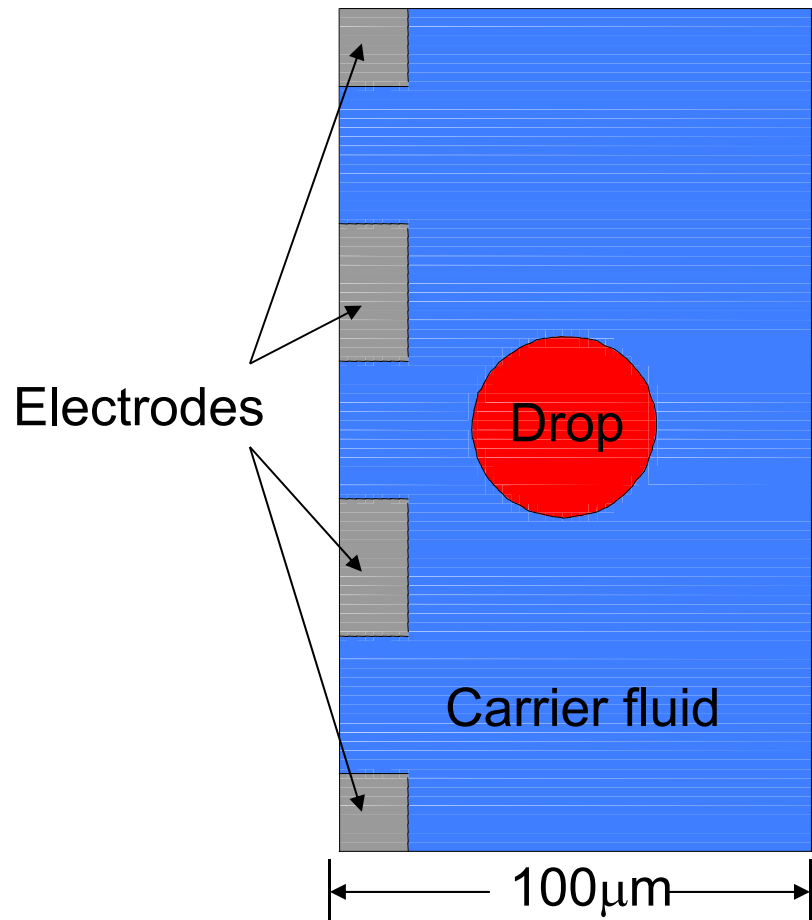

Dielectrophoresis (DEP):

Force acting on non-uniform dielectric materials in non-uniform electric field

Liquid drop can be moved by charging electrode

Considered effects:

- Fluid dynamics (two phase flow)
- Electrodynamics

FLOW SCIENCE

Electric Potential @ Time 0.1ms

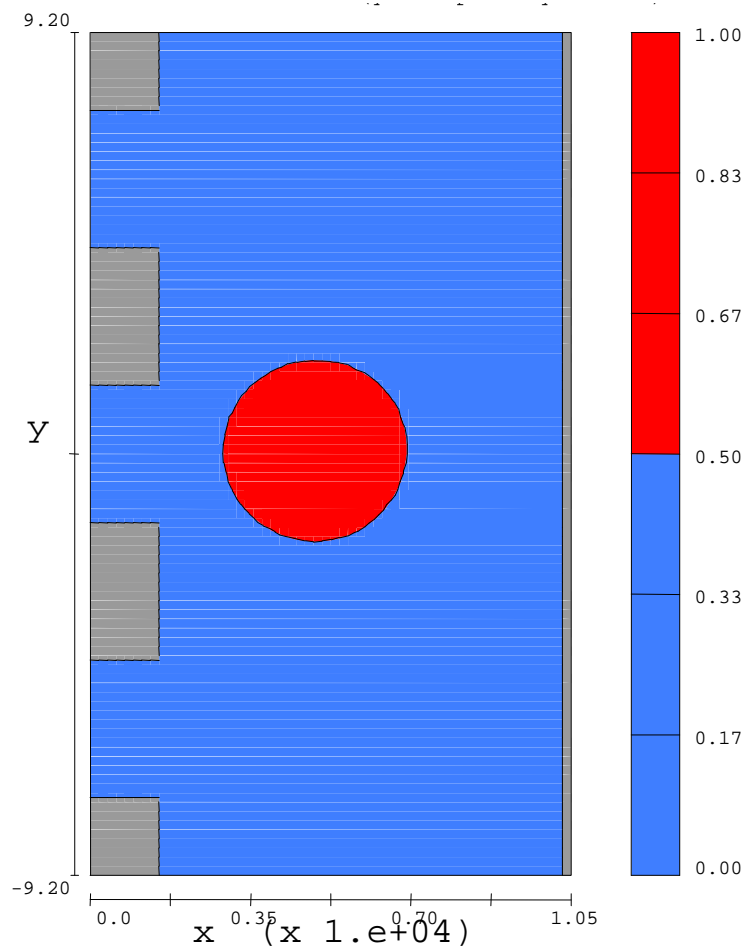

Droplet in carrier fluid
(Droplet has high dielectric constant)

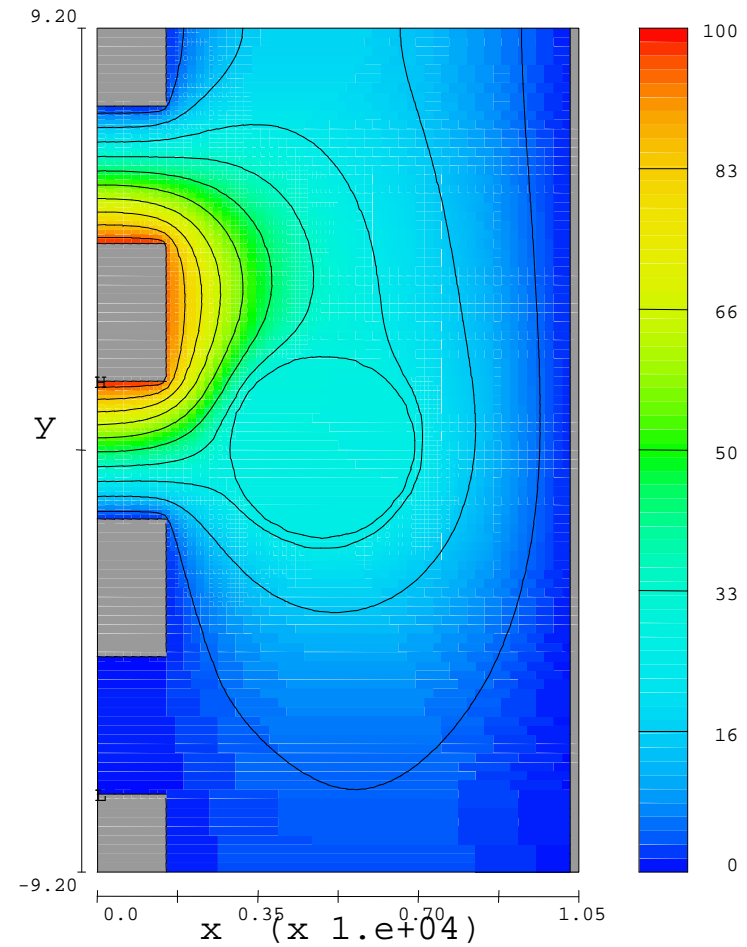

Potential field
(0 - 100 volts)

Electric Potential @ Time 0.7ms

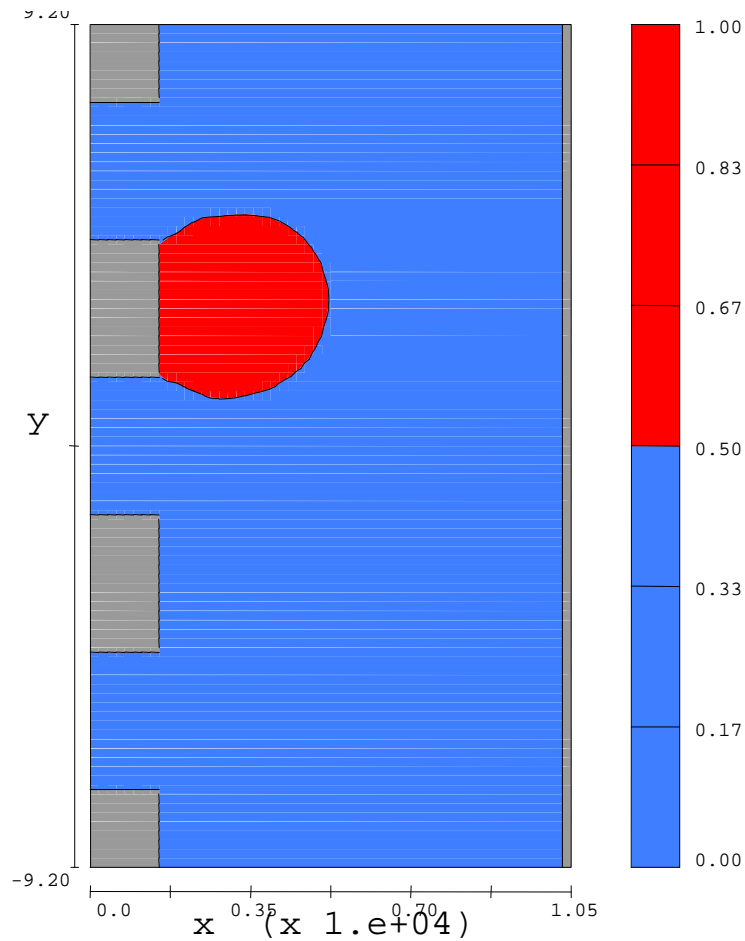

Droplet in carrier fluid
(Droplet has high dielectric constant)

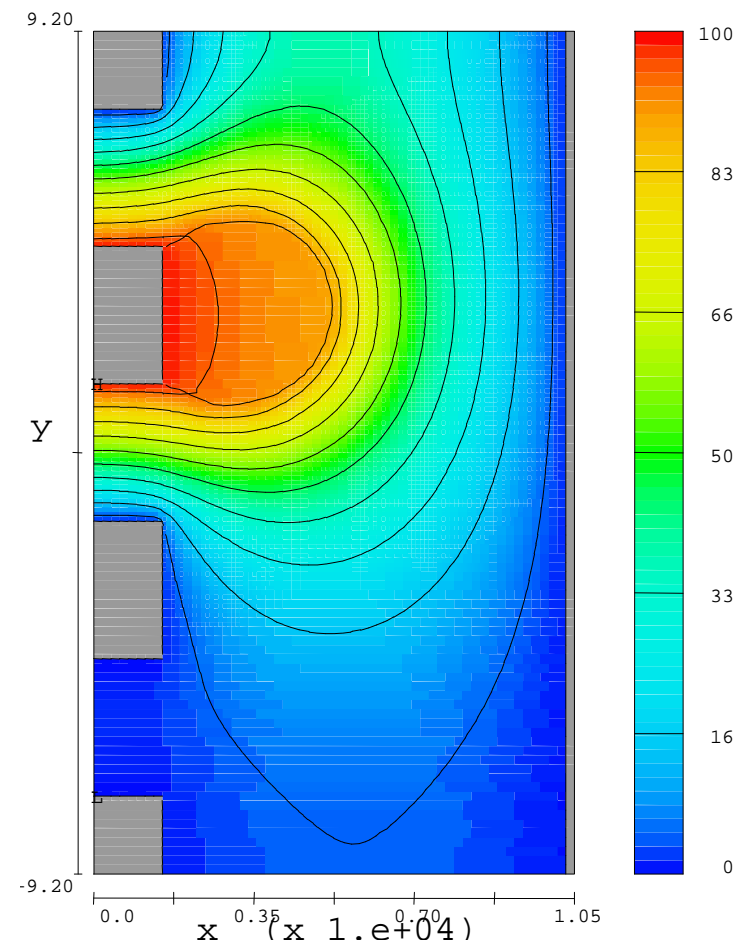

Potential field
(0 - 100 volts)

Example 4: Bubble-Jet Printhead

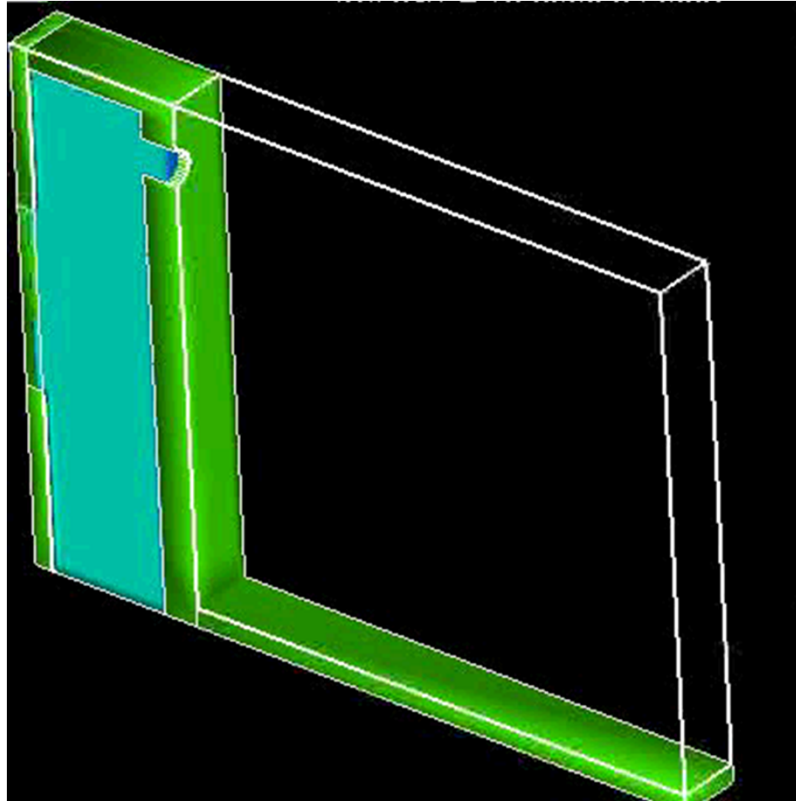

Considered effects:

- Fluid dynamics (two phase flow)
- Heat transfer
- Phase transition

Droplet Characteristics by Thermal Bubble Jet

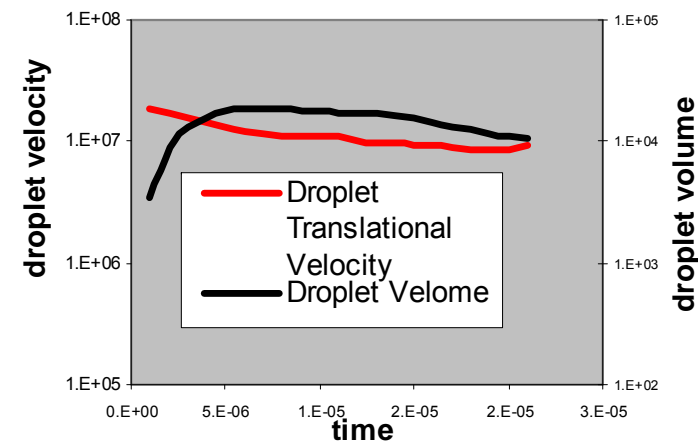

Example 5: Microarraying

Considered effects:

- Fluid dynamics (two phase flow)
- Adhesion & surface tension!

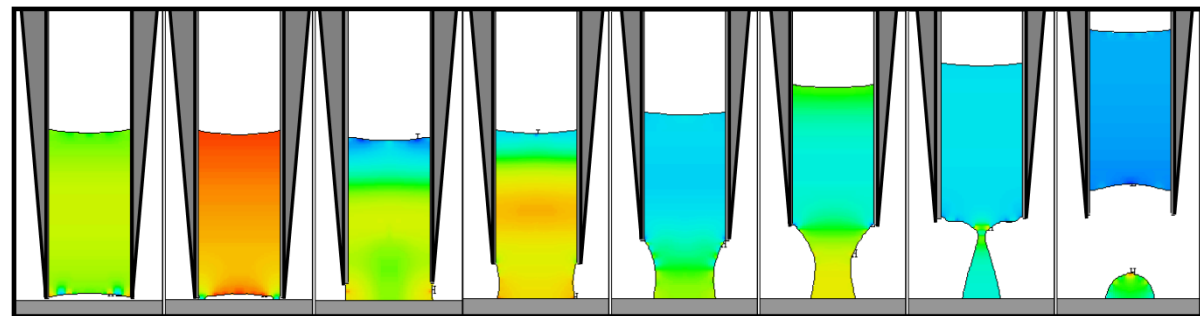
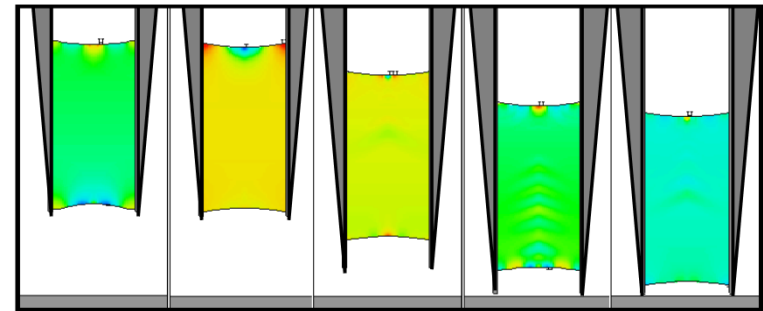
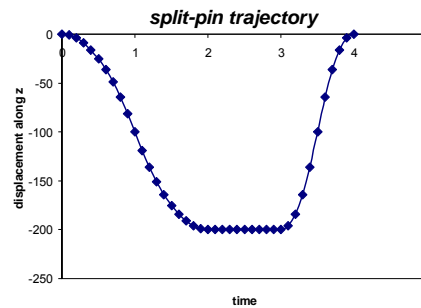
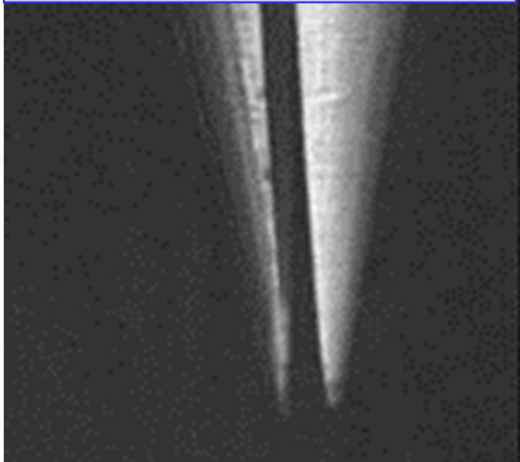

a split-pin fabricated by Brown group in Stanford University, a fine slot is machined into the end of the pin to accommodate liquid sample (courtesy professor Patrick O. Brown, Stanford University).



Example 6: Dispensing into Well

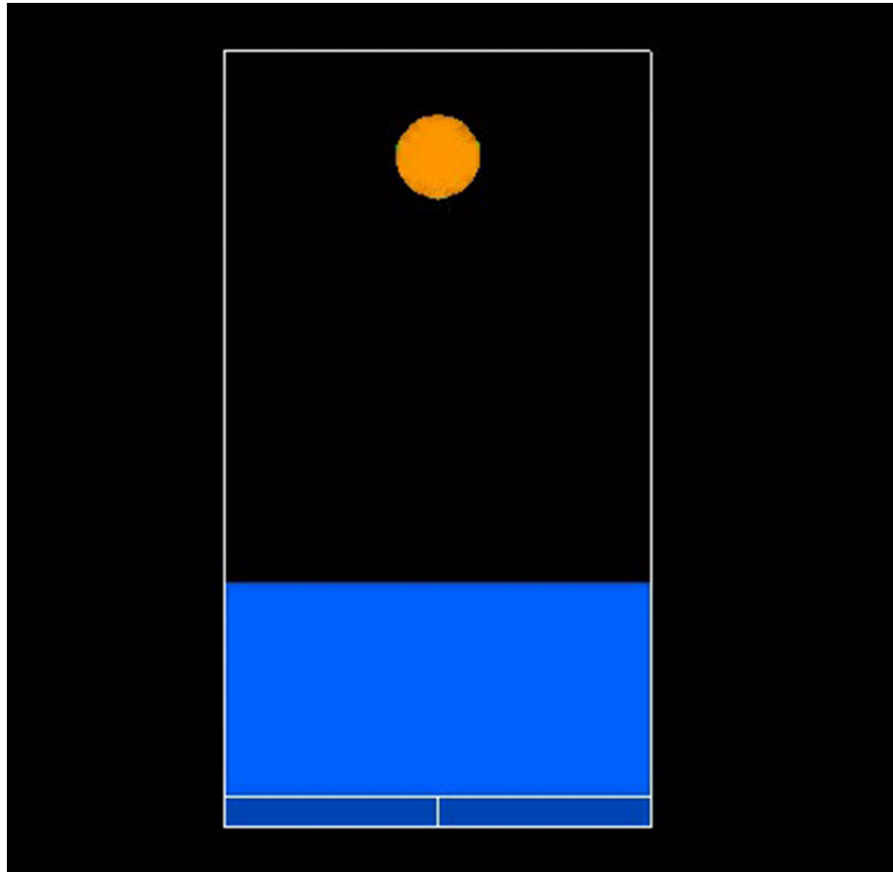

Considered effects:

- Fluid dynamics (two phase flow)
- Mixing



Example 7: Flap Valve

Considered effects:

- Fluid dynamics
- Fluid-structure interaction

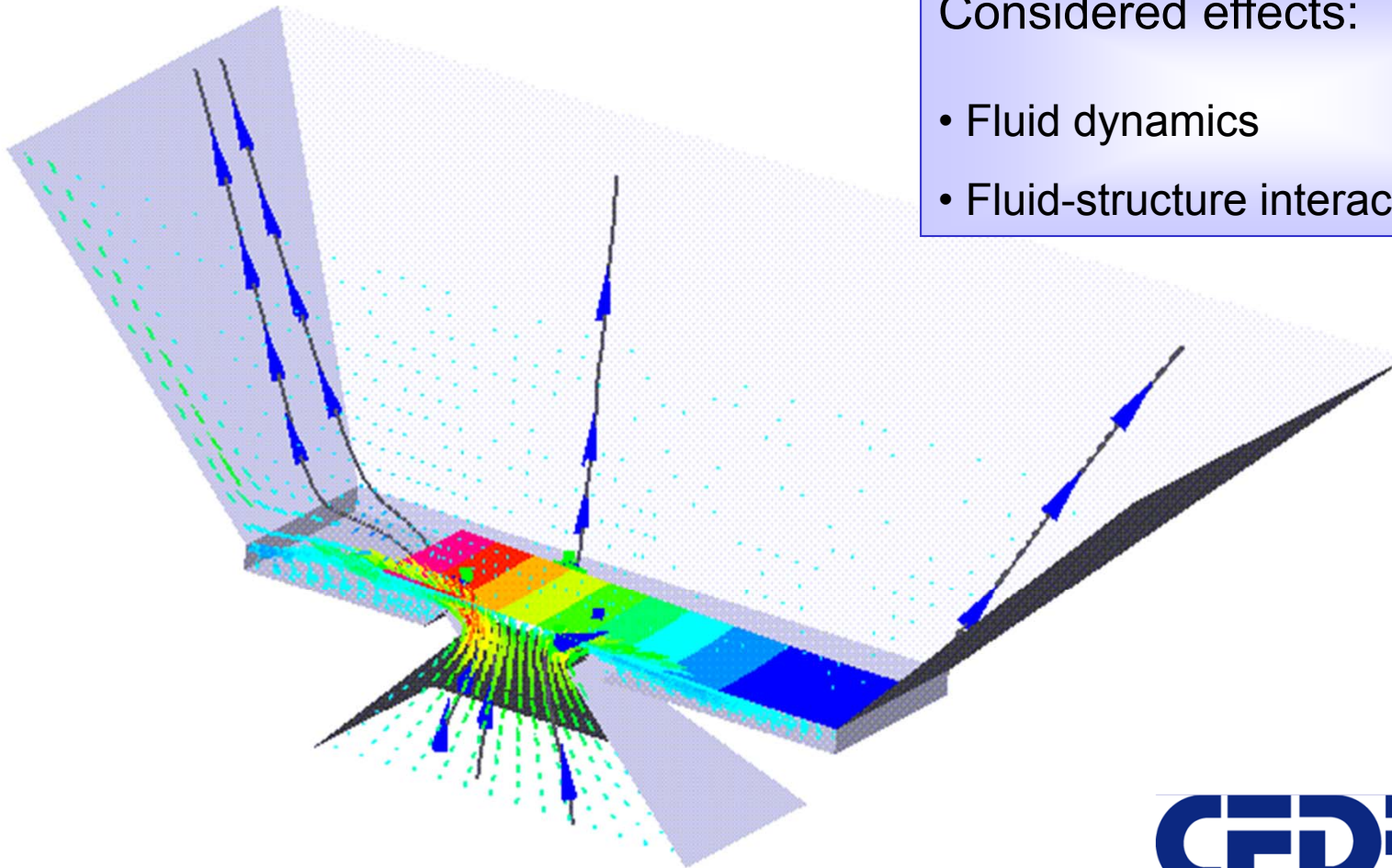

CFDRC

Top-Spot Microarrayer

- Contact-free method
- Maximum 384 different liquids
- Massively parallel printing
- Volumes 100 pl to a few nl

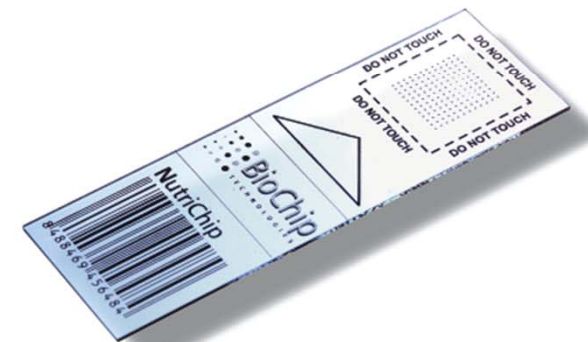
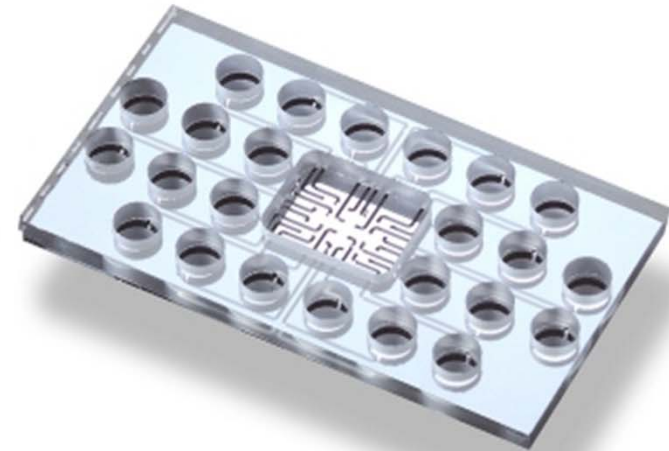
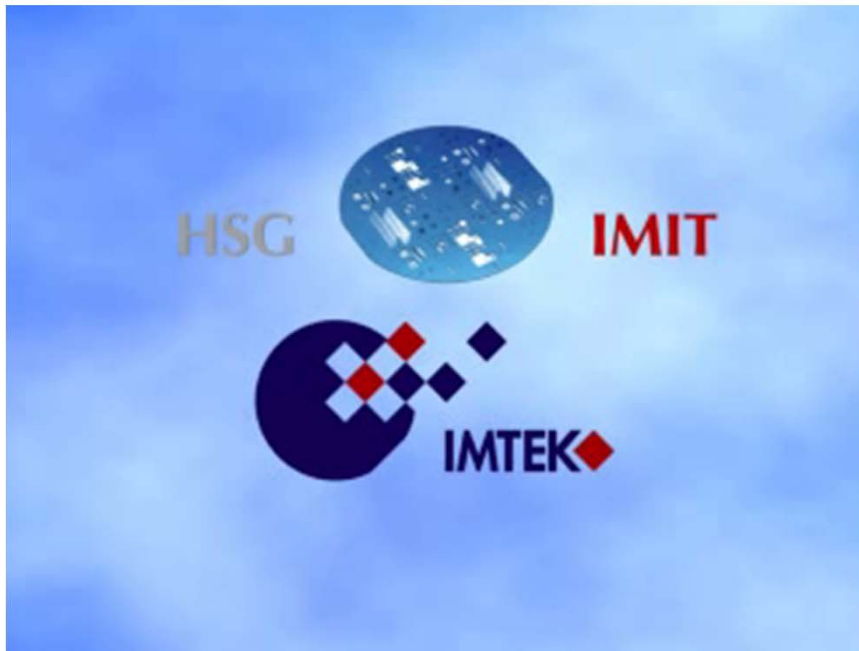

Simulation of Top-Spot

Simulation of displacement by moving

Simplifications

- Simplified pressure profile
- Only one nozzle
- Using symmetry

Questions

- Dosage volume dependent on maximum piston stroke ?
- Dependence of droplet generation on piston dynamics?
- Droplet velocity?

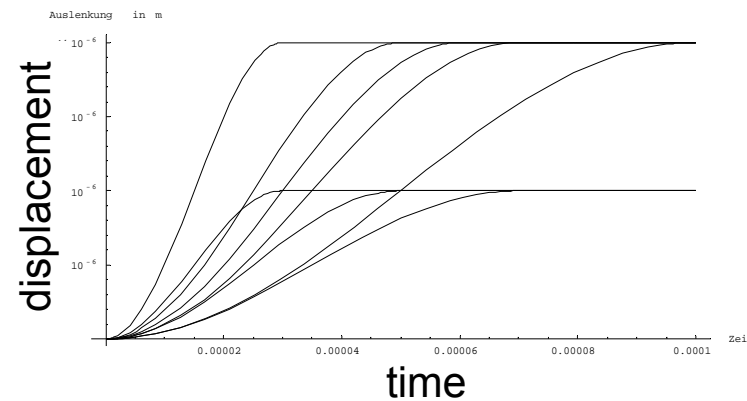
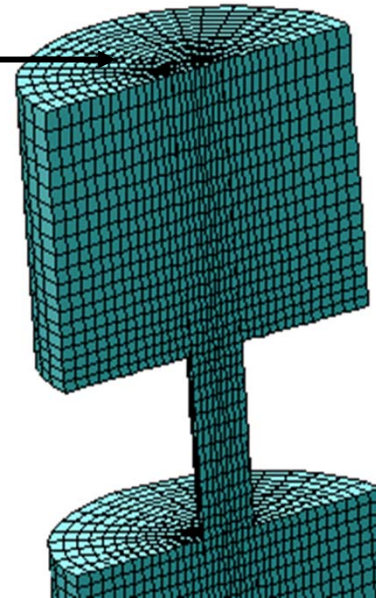

Dynamic Simulation

Stroke dynamics: $2\ \mu\text{m}$ / $30\ \mu\text{s}$

$2 \cdot 10^{-6}\text{m}$ Hub, $30 \cdot 10^{-6}\text{s}$ Anstiegszeit

0.000000s

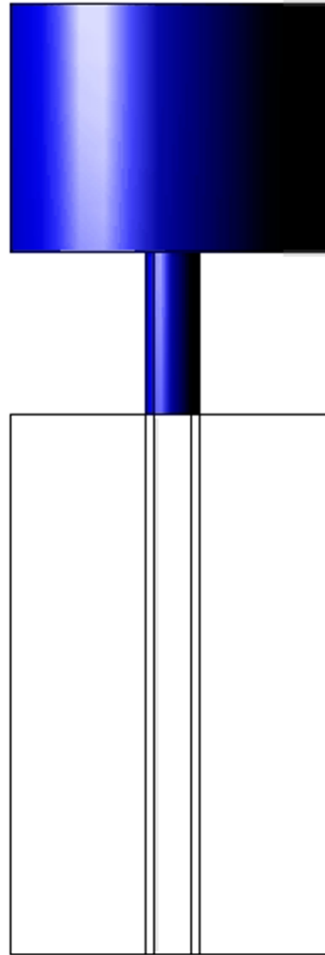

Dynamic Simulation

Stroke dynamics: $2\ \mu\text{m} / 50\ \mu\text{s}$

$2 \cdot 10^{-6}\ \text{m}$ Hub, $50 \cdot 10^{-6}$ Anstiegszeit

0.000000s

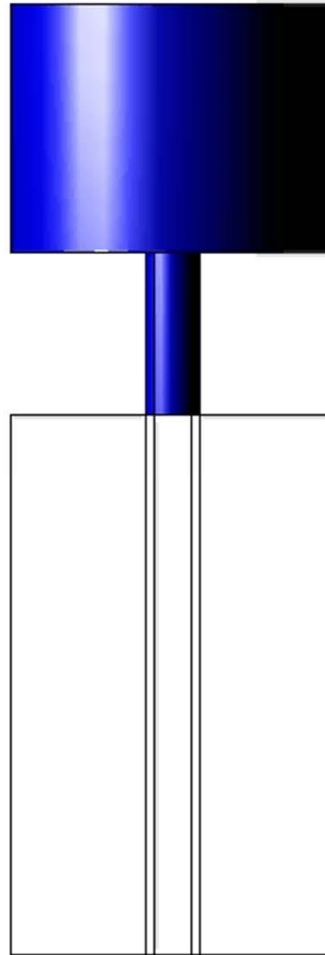

Dynamic Simulation

Stroke dynamics: $2\ \mu\text{m} / 70\ \mu\text{s}$

$2 \cdot 10^{-6}\ \text{m}$ Hub, $70 \cdot 10^{-6}$ Anstiegszeit

0.000000s

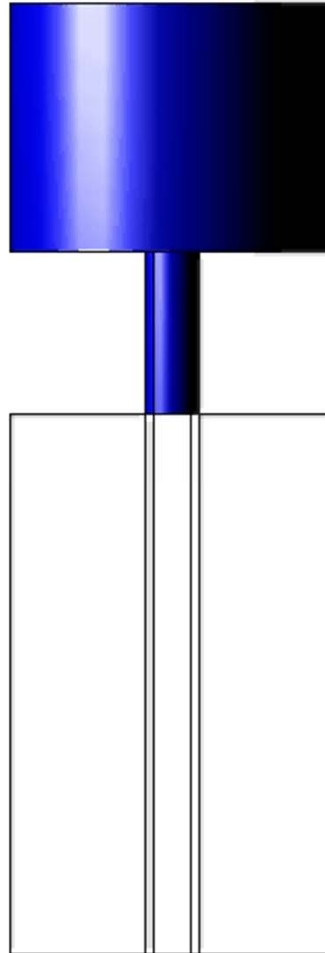

Results

Standard operation

- Fluid volume / piston stroke approx. linearly dependent
- Direct relation between piston dynamics and droplet velocity

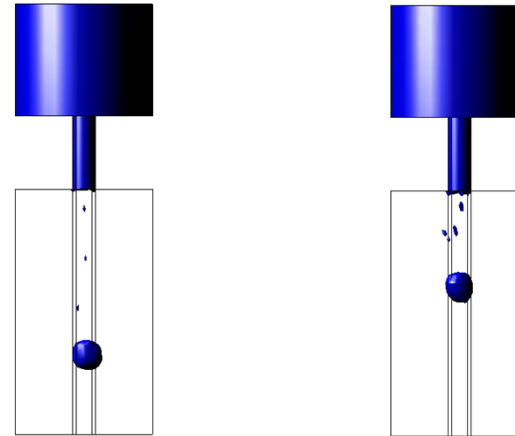

2 μm stroke, within 30 μs resp. 50 μs

Low piston dynamics

- Droplet may return to nozzle
- This has also been observed in experiments!

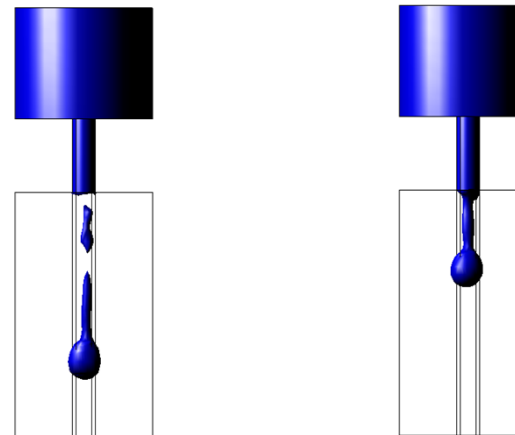

4 μm stroke, within 60 μs resp. 100 μs

3.A. Simulation

- Motivation: What is simulation good for?
- Two prominent types of simulation: CFD and system simulation
- CFD simulation:
 - Resources
 - Basics of the method
 - Examples
- System simulation
 - Resources
 - Basics
 - Examples
- Conclusions & Summary

System Simulation

Idea: Division of complex system into sub-systems, which can be described by **compact (“lumped” or “behavioral”)** models. Interactions between subsystems mediated **via network** of connections

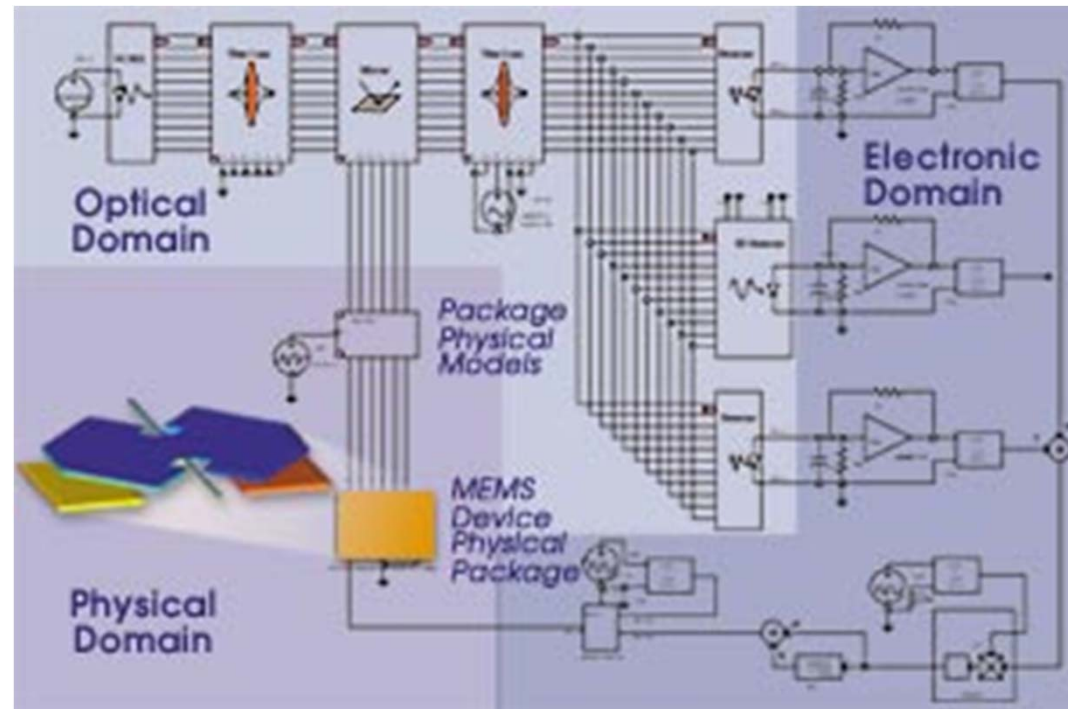

Resources

- General information on MEMS simulation tools (not only system simulation)
 - <http://www.memsnet.org/links/software.html>
 - Saber Simulator
 - <http://www.avanticorp.com/Avant!/SolutionsProducts/Products/Item/1,1500,65,00.html>
 - Spice Usergroup
 - <http://www.seg.iit.nrc.ca/spice/>
 - Eldo Simulator
 - <http://www.mentor.com/eldo/overview.html>
 - Mathlab
 - <http://www.mathworks.com/>
-

Electric Circuit Simulation

- Based on Kirchhoff's laws
 - Sum of all currents I_n at node is zero
 - Sum of all voltages U_n within closed loop is zero
- Differential equations derived from „transfer functions“ $U = f(I)$:
 - $U_R = R \cdot I$
 - $U_L = L \cdot dI / dt$
 - $U_{\text{source}} = R \cdot I + L \cdot dI / dt$
- Differential equations (DE) solved numerically (time- or frequency domain)

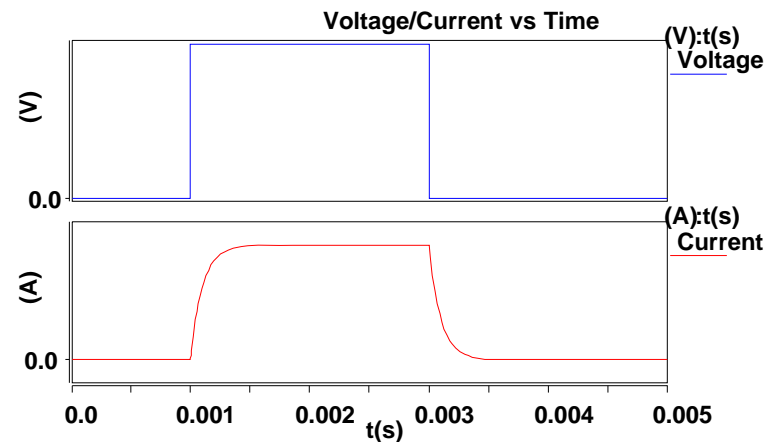
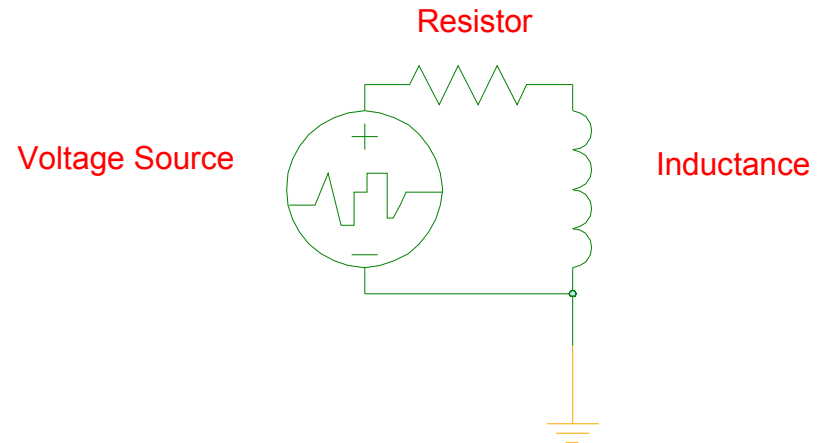

Analogy in Fluidics: $I \Rightarrow q$ and $U \Rightarrow p$

- Completely filled capillary
 - Ohmic resistance \rightarrow fluidic resistance
 - Viscosity
 - Geometry
 - Inductance \rightarrow inertia of fluid
 - Density
 - Geometry

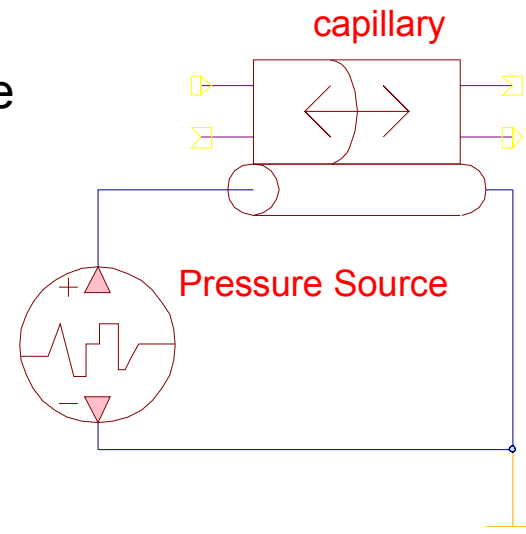

- Transfer functions and DE
 - $p_R = R \cdot q$
 - $p_L = L \cdot dq / dt$
 - $p = R_{\text{fluid}} \cdot q + L_{\text{fluid}} \cdot dq / dt$

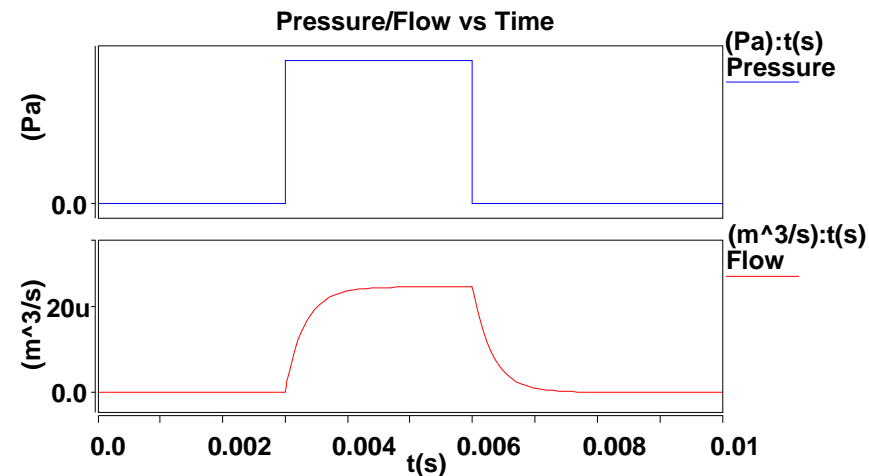

- Numerical solution

Fundamental Principle

“through“ variable + “across“ variable + conservation law = network simulation

Physical system described by field equations

$$\Psi[f(\vec{x}_0, t_0, \vec{x}, t)] = 0$$

Transition from locally dependent variables (e.g., current density) to integral quantities (e.g., current) at selected points in space (nodes)

Through and across variables at discret points (nodes)

$$\left\{ \begin{array}{l} u_1(t_0, t) \\ \vdots \\ u_n(t_0, t) \end{array} \right\}, \left\{ \begin{array}{l} i_1(t_0, t) \\ \vdots \\ i_n(t_0, t) \end{array} \right\}$$

Taking into account laws of conservation (e.g., continuity equation, conservation of energy) and modelling the transfer function (e.g., $R = U / I$)

Netlist & transfer functions

→ Differential equation for network simulation

$$\begin{pmatrix} u_1(t_0, t) \\ \vdots \\ u_n(t_0, t) \end{pmatrix} = \underline{\underline{M}}(t) \times \begin{pmatrix} i_1(t_0, t) \\ \vdots \\ i_n(t_0, t) \end{pmatrix}$$

Analogy in Many Physical Domains

[G.Gerlach, W.Dötzel, „Grundlagen der Mikrosystemtechnik“, Hanser Lehrbuch (1997)], S. 81

System	Flußgröße		Potentialgröße		Leistung P	Energie $W = \int P dt$	Energiedichte W/V
allgemein	Q	$F = dQ/dt$	x	$v = dx/dt$	$F \cdot v$	$F \cdot x$	$F \cdot x / V$
elektrisch	Ladung Q	Strom $i = dQ/dt$	- ¹⁾	Spannung u	$u \cdot i$	$Q \cdot u$	$E \cdot D / 2$
mechanisch (translatorisch)	Impuls $p = m \cdot v$	Kraft $F = dp/dt$	Weg s	Geschwindigkeit $v = ds/dt$	$F \cdot v$	$F \cdot s + m \cdot v^2 / 2$	$\epsilon \cdot \sigma / 2$
mechanisch (rotatorisch)	Drehimpuls L	Drehmoment $M = dL/dt$	Winkel φ	Winkelgeschwindigkeit $\Omega = d\varphi / dt$	$M \cdot \Omega$	$M \cdot \varphi + J \cdot \omega^2 / 2$	$\gamma \cdot \tau / 2$ bzw. $\epsilon \cdot \sigma / 2$
akustisch, hydraulisch, pneumatisch	Volumen V	Volumenfluß $q = dV/dt$	Druckstoß $S = \int p dt$	Druck p	$V \cdot p$	$q \cdot p$	$q \cdot p / V$
thermisch	Wärmemenge Q_{th}	Wärmestrom $\Phi_{th} = dQ_{th} / dt$	- ¹⁾	Temperatur ΔT	Φ_{th}	Q_{th}	Q_{th} / V
	Entropie $S = \int (1/T) dQ_{th}$	Entropiefluß $\dot{S} = dS / dt$	- ¹⁾	Temperatur T	$T \cdot S$	$Q_{th} + T \cdot S$	$\frac{Q_{th} + T \cdot S}{V}$
magnetisch	- ¹⁾	magnetischer Fluß Φ_m	magnetische Spannung V_m	- ¹⁾	- ¹⁾	$\Phi_m \cdot V_m$	$B \cdot H / 2$
optisch	Lichtmenge $Q_R = h\nu n$	Lichtstrom $\Phi_R = dQ_R / dt$	Belichtung $H_R = \int E_R dt$	Beleuchtungsstärke $E_R = d\Phi_R / dA$	Φ_R	Q_R	Q_R / V

How to obtain transfer functions?

- Analytical solution of fundamental differential equation, e.g.,
 - Ohmic resistance
 - Inductance
 - Empirical compact models, e.g.,
 - Diode models
 - Tubular flow
- Experimental or simulation data (grid-based simulations), e.g.,
 - Look-up tables
 - Couple simulations
- Automated model reduction techniques, example on next slide

Model Reduction Techniques

Reduction of degrees of freedom (DOF) e.g., with singular value decomposition (SVD) or modal analysis, etc.

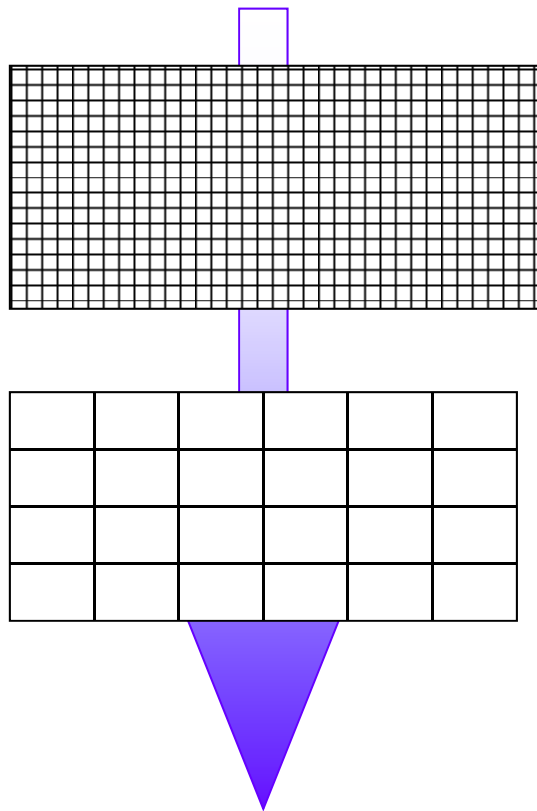

Approximation of solution obtained from physical modeling e.g., with nonlinear fit or neural networks, etc.

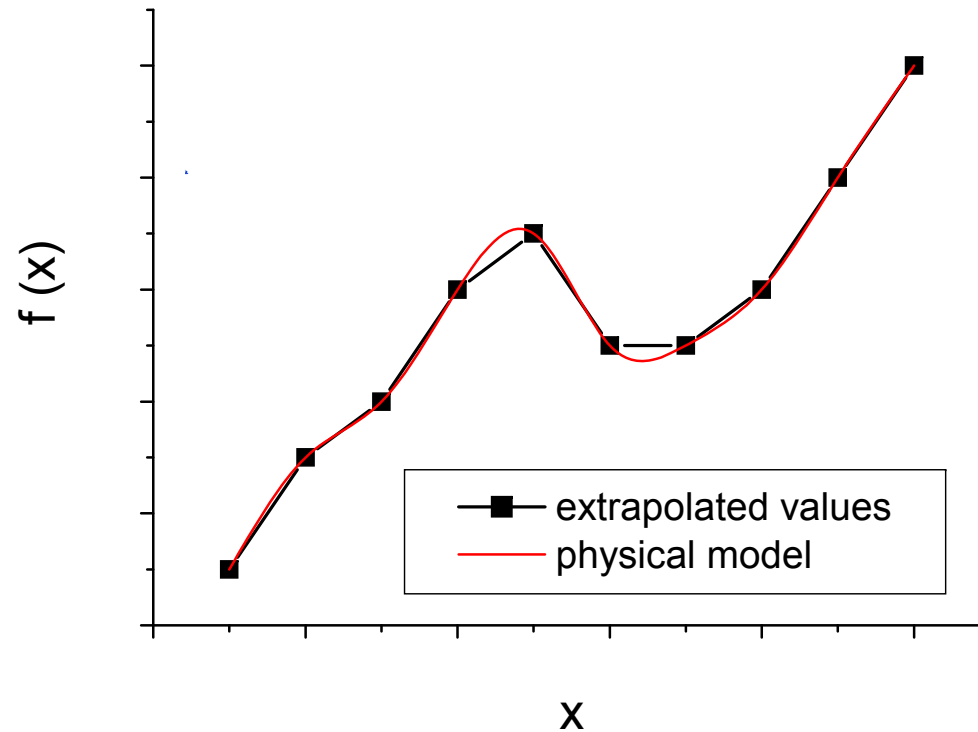

Example 1: Capillary Model

- Capillary states
 - *empty*: only air flow considered
 - Transition state: *wet1dry2* (filling from one end); *wet2dry1* (vice versa)
 - *Full*: resistance according to tube flow
- Nozzle states
 - *empty* and *wet2dry1* identical
 - Additional consideration of *meniscus state* ($p < 2 p_{\text{cap}}$)
 - In *eject-state* ($p > 2 p_{\text{cap}}$) approximation of pressure drop by Toricelli's formula

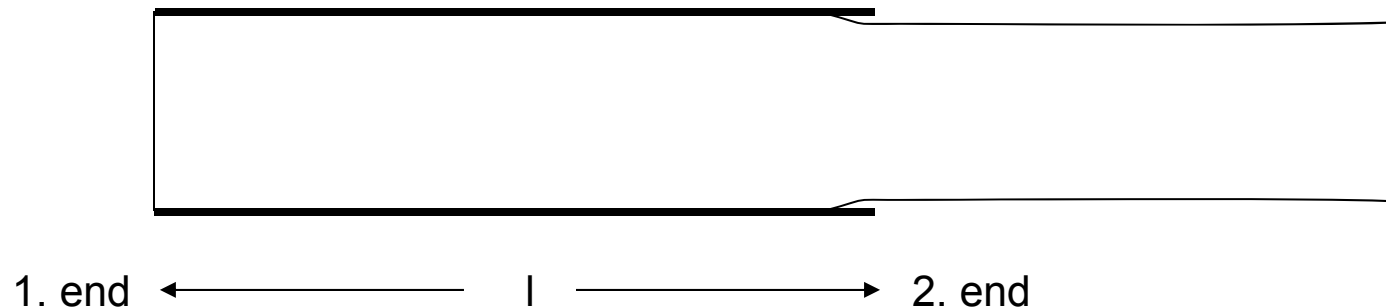

Capillary Channel

Capillary channel with circular cross section ($\varnothing d$, length l):

Capillary pressure p_{cap} , laminar flow resistance R , fluidic inductance L and position of meniscus are considered

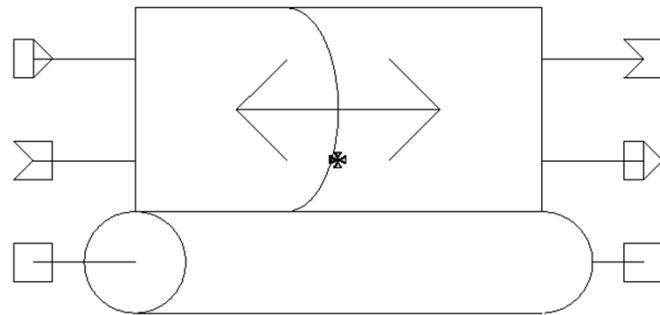

logical pin input

logical pin output

fluidic line

din:*req*

len:*req*

$$p = Rq + p_K + p_i$$

↑ resistance
 ↑ capillary pressure
 ↑ inertia

$$R = \frac{8\eta l}{\pi^2 (d/2)^4}; \quad L = \frac{l}{\pi (d/2)^2 \rho}; \quad p_K = \frac{\sigma}{d}; \quad p_i = \frac{d}{dt}(Lq)$$

Capillary Nozzle

Capillary nozzle with circular cross section ($\varnothing d$, length l):

Capillary pressure p_{cap} , laminar flow resistance R , fluidic inductance L and free jet ejection are considered

logical pin input

logical pin output

fluidic line

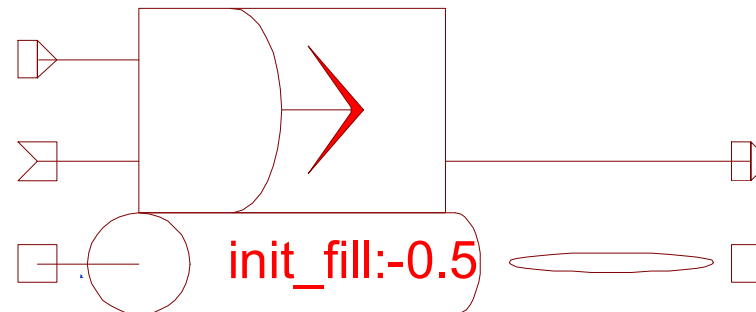

din:Diameter

len:Length

$$q = \begin{cases} 0 & ; p < 8\sigma / d \\ \mu \frac{\pi}{4} d^2 \sqrt{\frac{2p}{\rho}} & ; p \geq 8\sigma / d \end{cases}$$

← No ejection: pressure smaller than $2 p_{\text{cap}}$

← Ejection: Torcelli's formula

Validation of Capillary Model

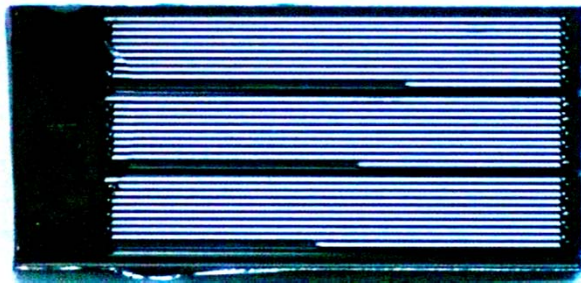

by priming of meandering capillaries

← experiment

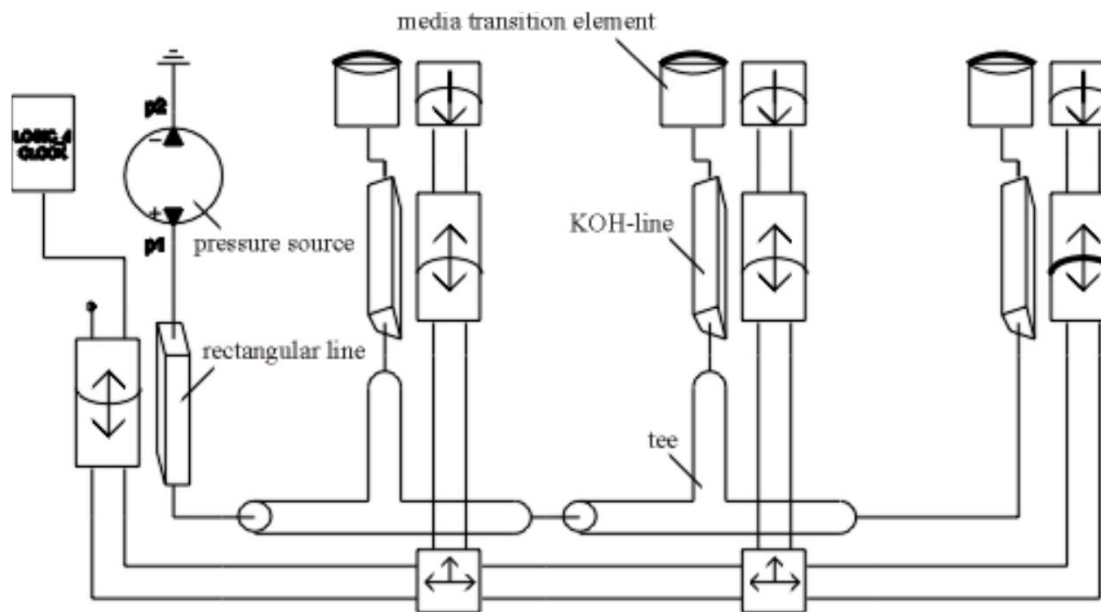

system model

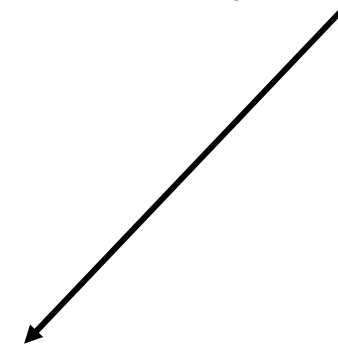

[Sesterhenn et.al MSM conference 1999, 538-541 Cambridge, MA]

Comparison with Measurements

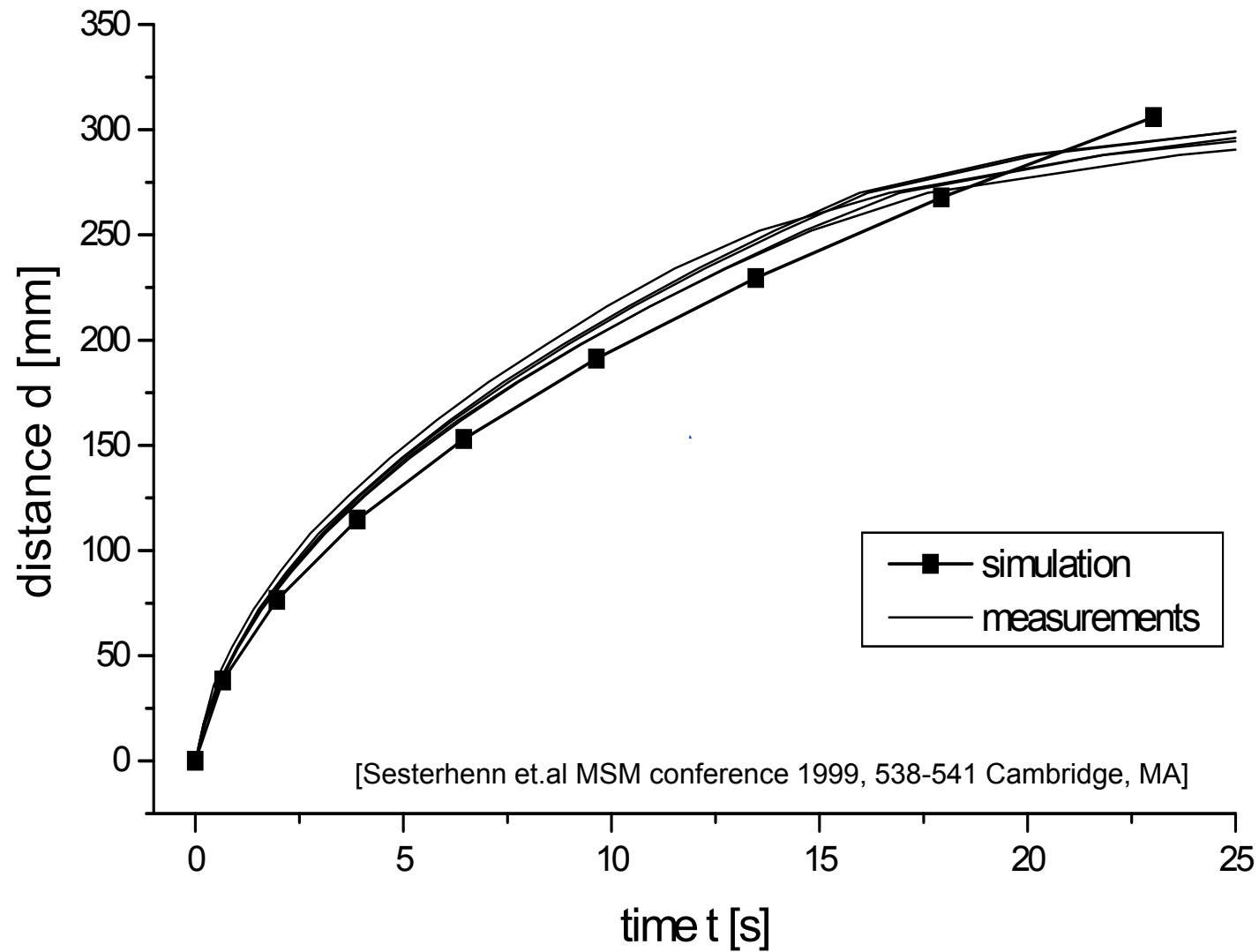

Validation of Nozzle Model

Simple multi channel test system

- Representing simple dispenser
- Micromachined in silicon
- Well suited for validation

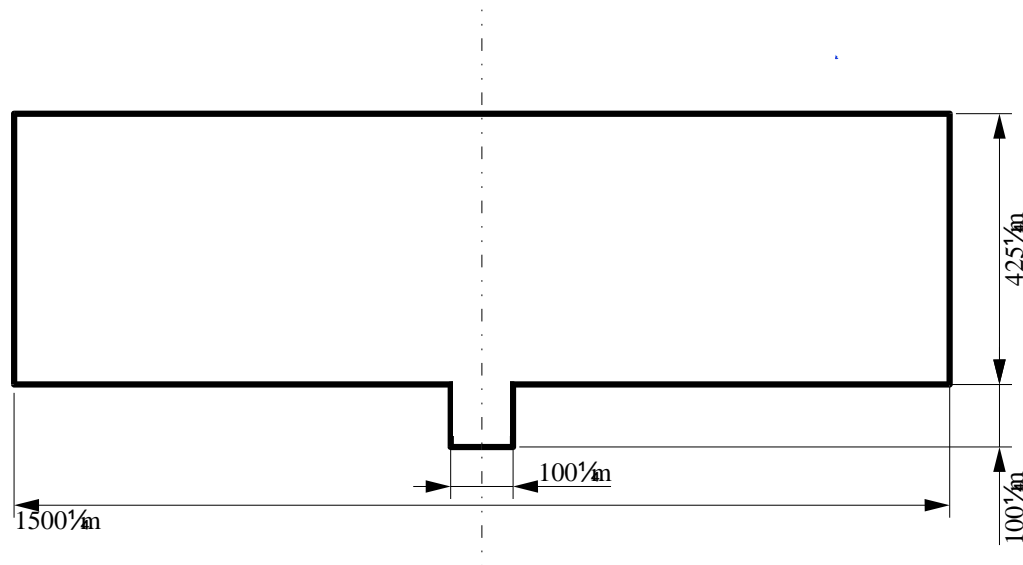

System Model

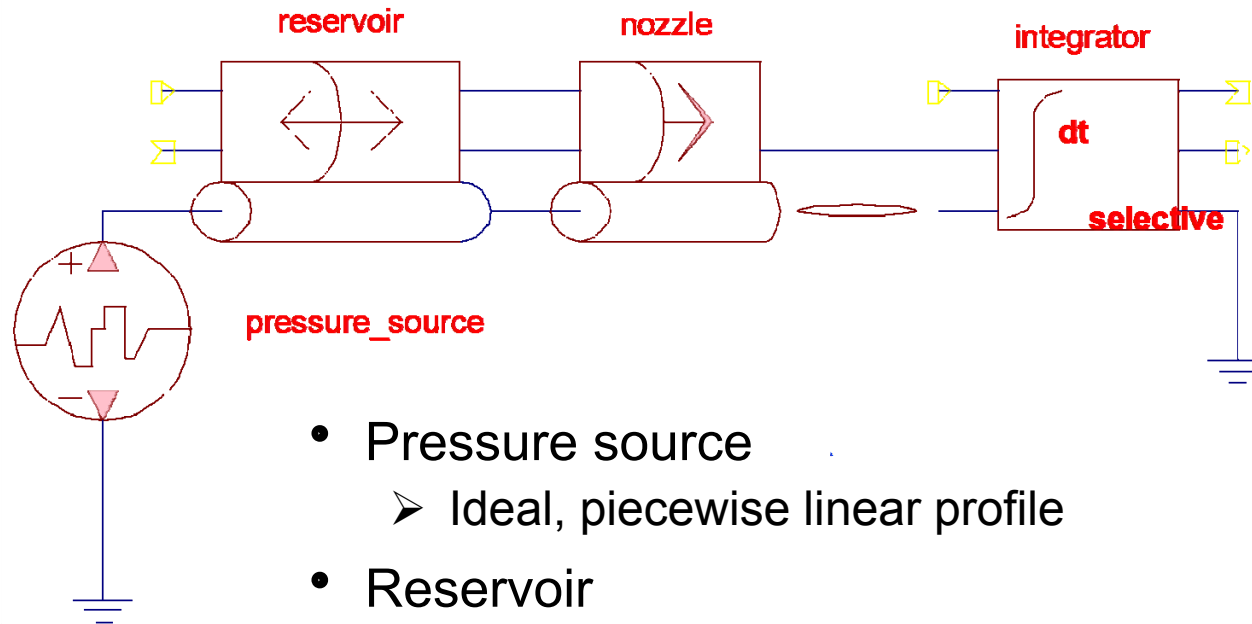

- Pressure source
 - Ideal, piecewise linear profile
- Reservoir
 - Capillary with 1500 μm diameter and 425 μm length
- Nozzle
 - 100 μm diameter, 100 μm length
- Integrator
 - Selective to fluid

Simulation Results in Time Domain

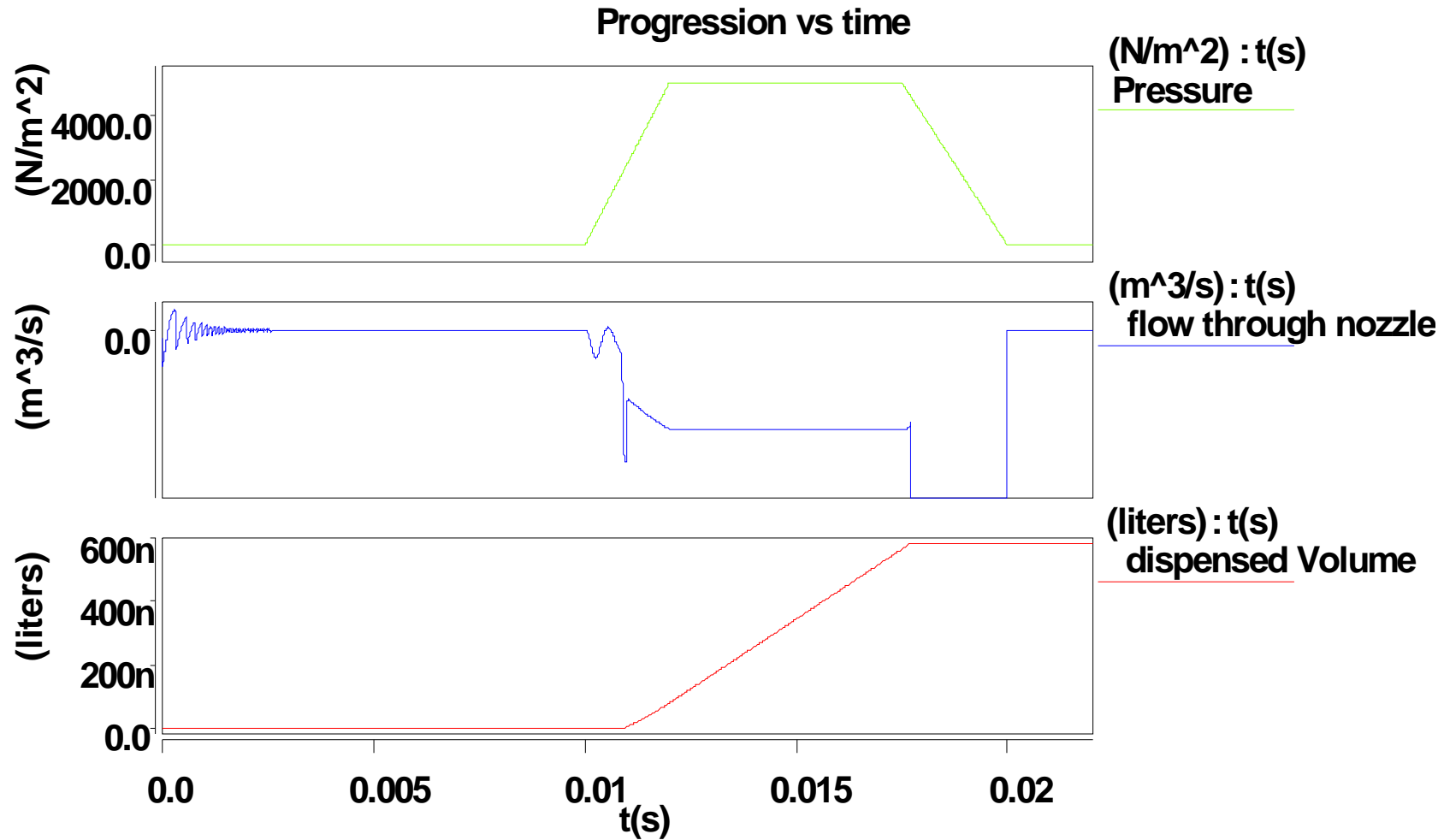

Comparison with Measurements

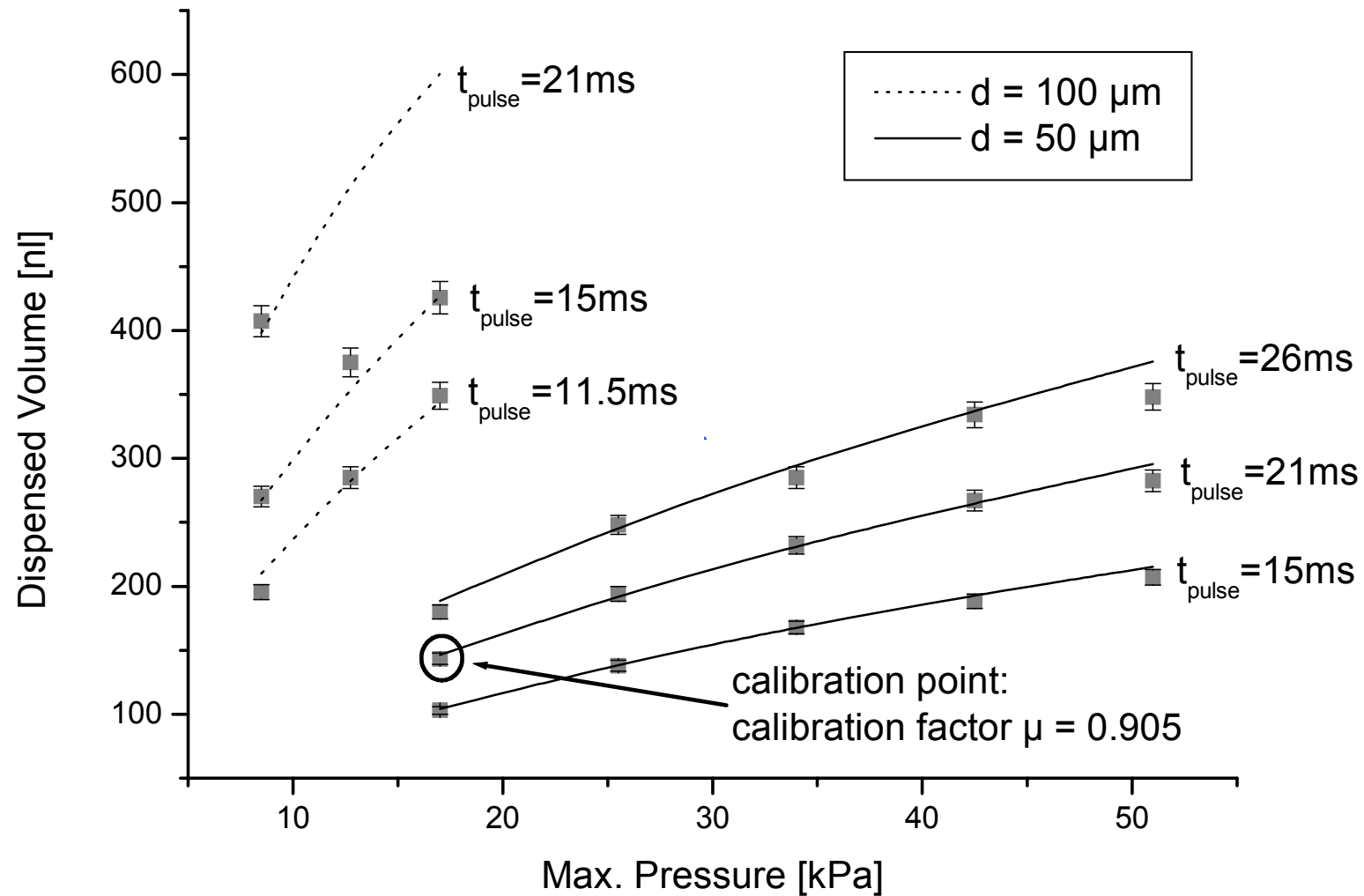

Example 2: Systemmodel for VAMP

Micro valve & micro diaphragm pump
(Valve And Micro Pump (VAMP))

[HSG-IMIT, Villingen-Schwenningen]

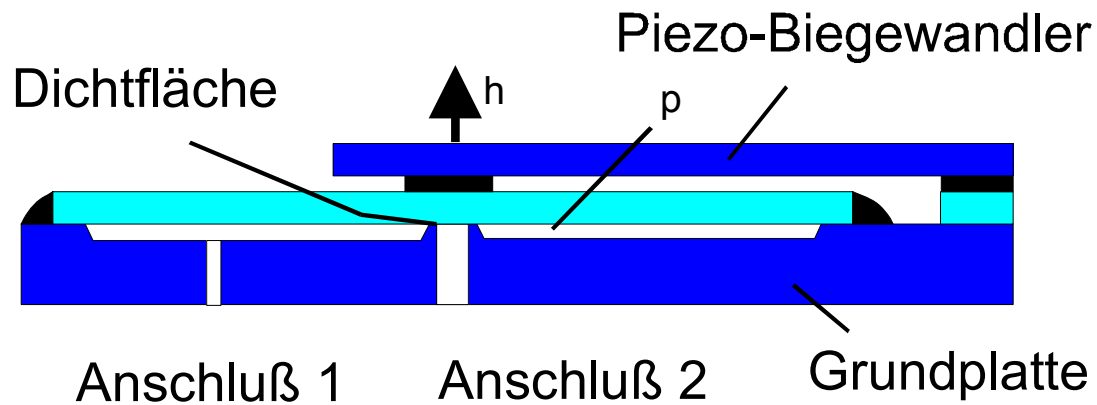
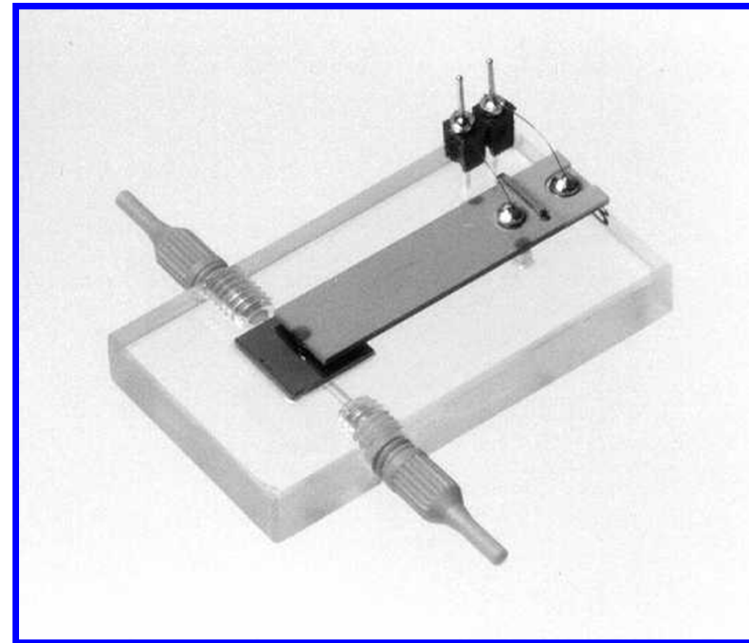

Network model of VAMP

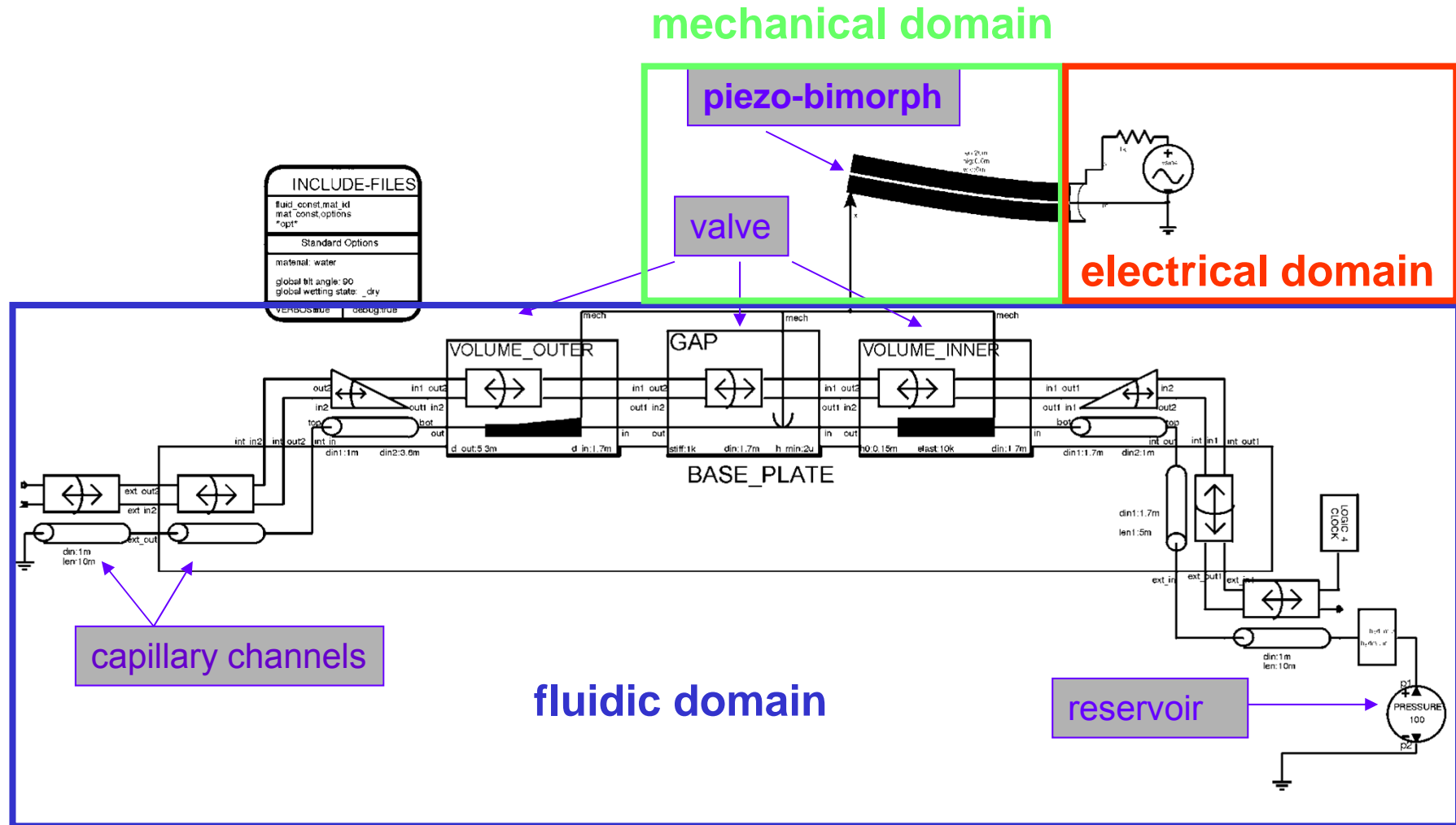

Simulation of Valve Operation

opening and closing cycle

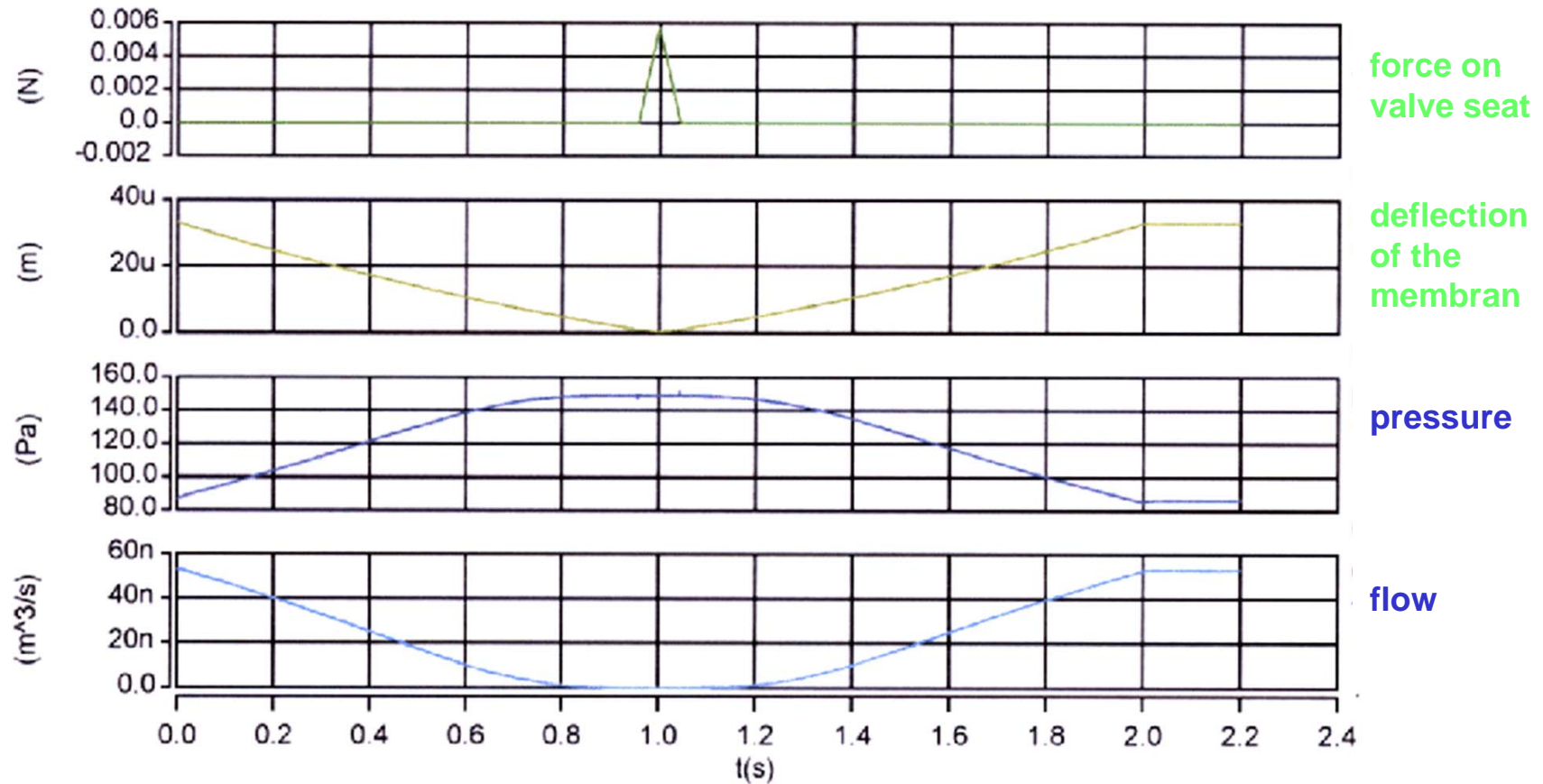

Micro Valve Characteristics

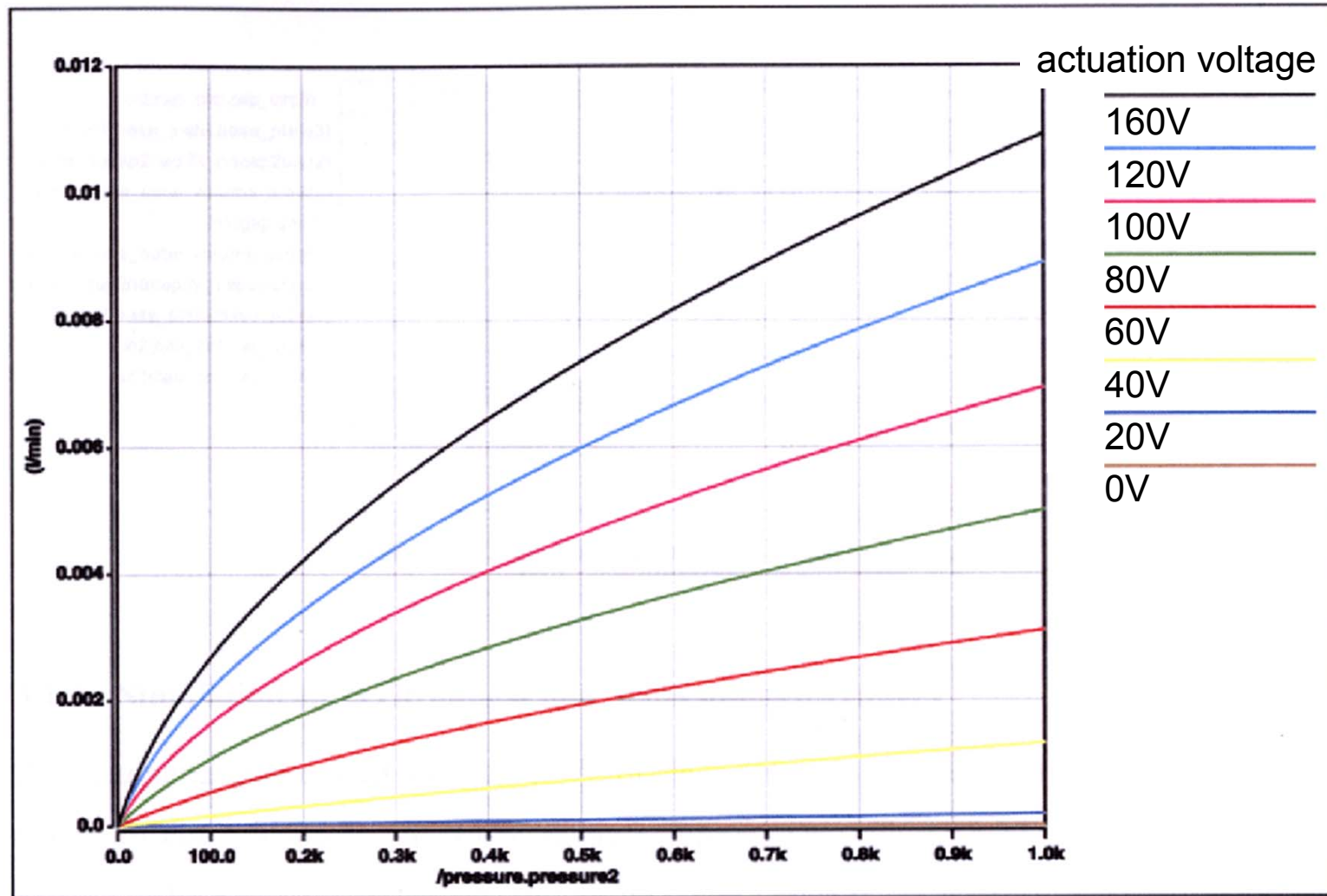

3.A. Simulation

- Motivation: What is simulation good for?
- Two prominent types of simulation: CFD and system simulation
- CFD simulation:
 - Resources
 - Basics of the method
 - Examples
- System simulation
 - Resources
 - Basics
 - Examples
- Conclusions & Summary

Comparison: CFD & Network Simulation

CFD $\rightarrow \Phi(\mathbf{x},t)$ (continuous in space and time)	network $\rightarrow \Phi_n(t)$ (discrete in space, continuous in time)
<p>DE <u>known</u>: Navier-Stokes-equations (including required “special effects“). DE is fundamental, universal</p>	<p>DE <u>unknown</u>, calculated on basis of netlist and transfer functions DE only valid for actual system</p>
<p>To do: geometry, boundary conditions and material properties have to be specified</p>	<p>To do: Division of the system in sub-systems, modeling of transfer functions and determining model parameters</p>
<p>Simulation: Solving 3-D <u>partial DE</u> on grid by approximate methods in space and time (\rightarrow mesh generation, solver, post processing)</p> <p>Time consuming & accurate</p>	<p>Simulation: Solving time dependent <u>ordinary DE</u> at discrete points (nodes) (\rightarrow linearization, matrix methods)</p> <p>Fast & especially suited for large systems</p>

Conclusions

Numerical Simulations of microfluidic systems ...

- Can be carried out with various methods
 - CFD => **computation costly**, however accurate
 - Network simulation => **fast**, however challenging due to model generation (few compact models available)
- Methods have to be appropriately chosen
 - CFD => problem for which **geometry** plays crucial role
 - Network simulation => **system simulations** with many „simple“ strongly interacting components
- Have different methodical & numerical background
 - CFD => solution in **time- and space**; complete, fundamental physical description
 - Network simulation => solution in **time at discrete nodes**; behavioral modeling using compact models